

**B**<sup>®</sup>  
**U**  
**T**  
**C**  
**H**  
**E**  
**R**  
**B**  
**O**  
**Y**

**PARTS MANUAL FOR BUTCHER BOY  
MODELS B14 S/N 4-6656 TO 4-20642  
ELECTRIC MEAT, FISH AND BONE SAWS**

(THAT WERE MANUFACTURED BY "LASAR MFG") UNTIL 1988  
AMERICAN MEAT EQUIPMENT HAD NO CONNECTION TO THE  
DESIGN, MANUFACTURING OR SALES OF THESE MACHINES

**B14**

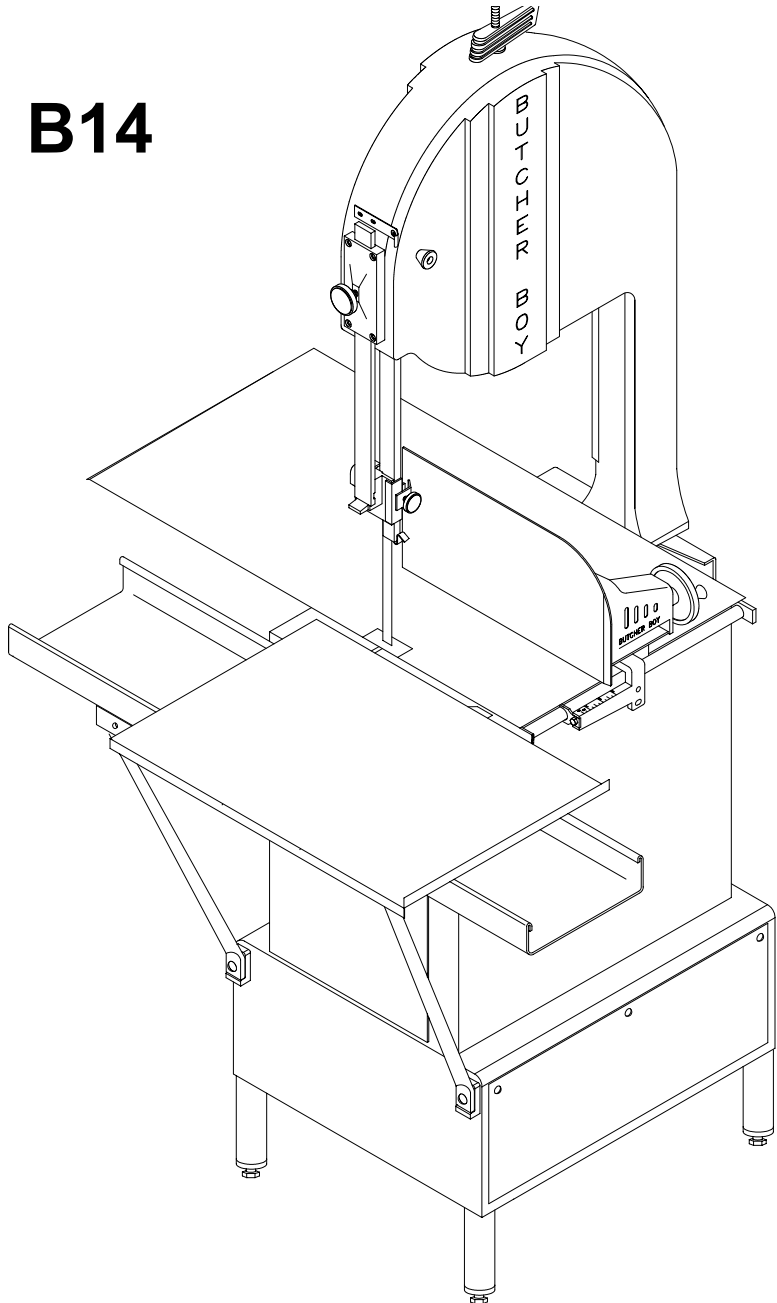

®

**American Meat Equipment Corp.**

1625 S. Greenwood Ave.

Montebello, Ca. 90640

Phone: (323) 724-5348

Fax: (323 ) 838-4336

# BUTCHER BOY B14 BAND SAW

<b>BUTCHER BOY B14 BAND SAWS INDEX</b>	
<b>DESCRIPTION</b>	<b>PAGE #</b>
B14 DOORS, COVERS, AND MISC.	1
B14 UPPER WHEEL ASSEMBLY	2
B14 UPPER WHEEL AND HANGER ASSEMBLY	3
B14 LOWER WHEEL ASSEMBLY	4
B14 FRONT SCRAPER ASSEMBLY	5
B14 REAR BLADE SCRAPER ASSEMBLY	6
B14 UPPER BAR GUIDE ASSEMBLY	7
B14 THICKNESS GAUGE ASSEMBLY	8
B14 TABLES AND SUPPORTS	9
B14 MOTOR AND DRIVE COMPONENTS	10
B14 SPARE PART KITS, FOR STD AND HI SPEED	11
SWITCH INDEX	12
S0 1 STARTER ASSEMBLY AND COMPONENTS	13
S0 2 STARTER ASSEMBLY AND COMPONENTS	14
S0 3 AND SO 4 STANDARD MANUAL SWITCH AND COMPONENTS	15
S0 5 STARTER ASSEMBLY AND COMPONENTS	16
B14 TENSIONING INSTRUCTIONS	17
B14 LUBRICATION INSTRUCTIONS	18

# BUTCHER BOY B14 BAND SAW PARTS

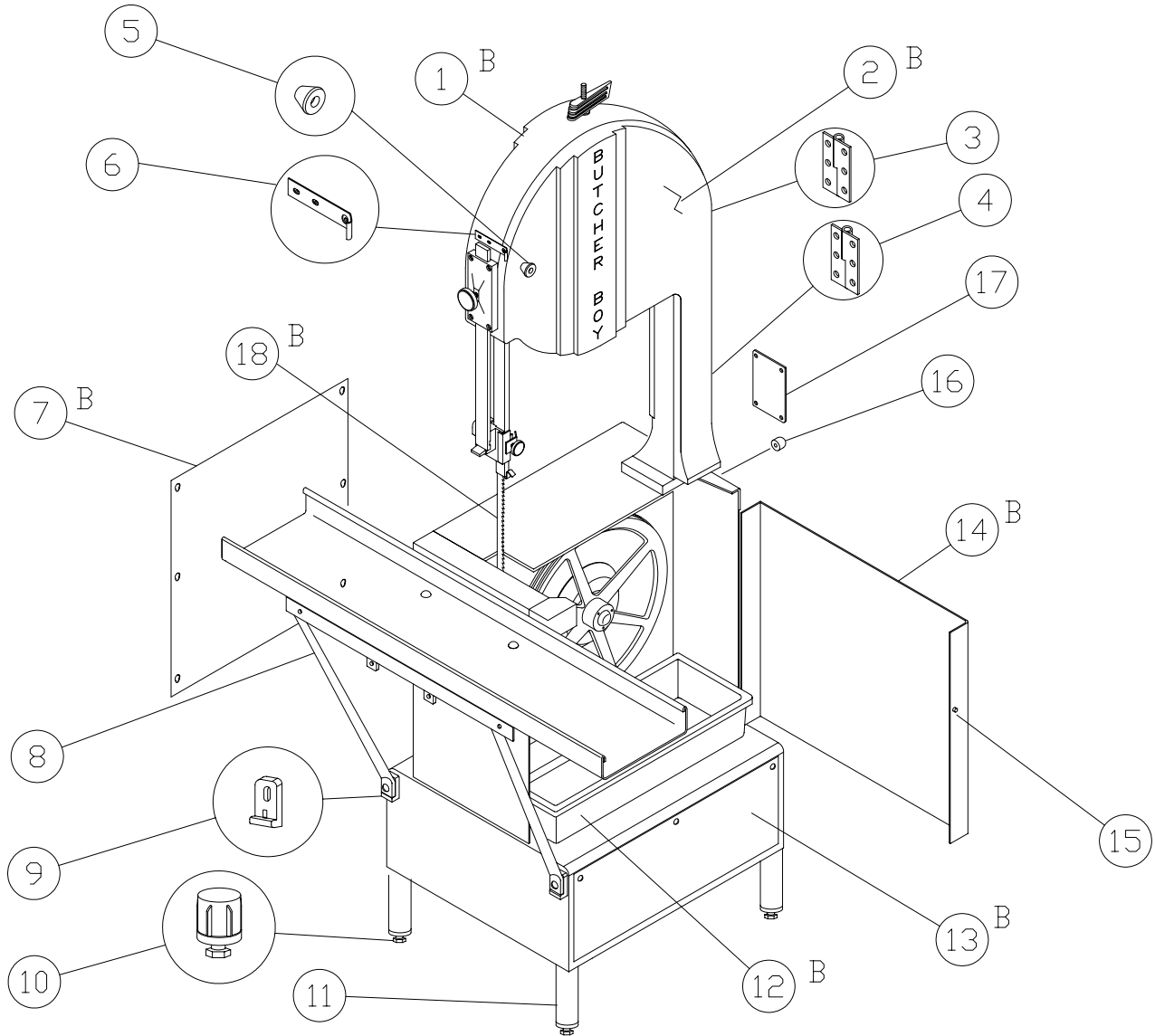

ITEM	PART#	DESCRIPTION	USE	ITEM	PART#	DESCRIPTION	USE
*1B		B14 ALUM. HEAD		11	0010370S	SS LEG & FOOT ASSY	4
*2A		B14 ALUM. DOOR		12B	0014069	B14 BONE BOX	1
3	0010606	UPPER HINGE ASSY	2	13B	0014108	B14 LOWER COVER	2
4	0010607	LOWER HINGE ASSY	2	14B	0014109	B14 SS BOTTOM DOOR	1
5	0010151	DOOR KNOB	2	15	FHSS-15-04-SS	DOOR STUD	2
6	0010272	DOOR LATCH	2	16	0090601	BUMPER	1
7B	0014106	B-14 REAR COVER	1	17	0010198	COVER	1
8	0010014S	SS BRACE	2	18B-E	0090852-E	B14 STD BLADE ECONOMY	6
9	0010260	BRACE ADJ. BRACKET	2	18B-H	0090852-H	B14 STD BLADE HARD TOOTH	6
10	0059390	FOOT ASSY	4				

\* NOTES: IT MAY BE POSSIBLE THAT THIS PART CAN BE REPAIRED IF SHIPPED TO AMERICAN MEAT EQUIPMENT CORP. (CALL BEFORE SHIPPING) 323-724-5348

# BUTCHER BOY B14 UPPER WHEEL ASSEMBLY

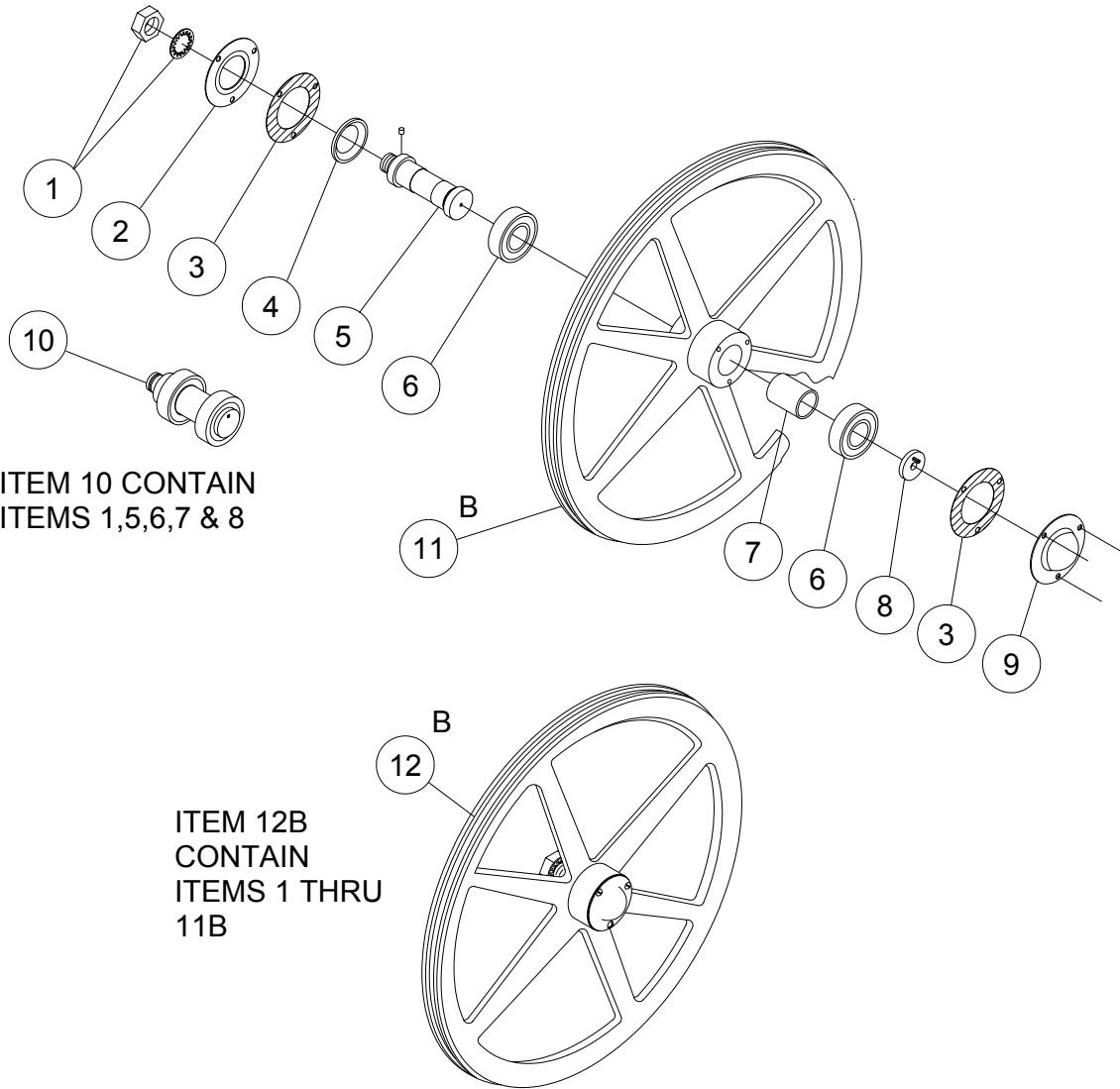

ITEM	PART#	DESCRIPTION	USE
1	0010770	NUT & WASHER-WHEEL SHAFT	1
2	0010030	BEARING RETAINER	1
3	0010127	GASKET	2
4	0090400	RUBBER SEAL	1
5	0010018	UPPER SHAFT W/ NUT & WASHER	1
6	0090302	BEARING – UPPER SHAFT	2
7	0010258	SPACER – BEARINGS	1
8	0010121S	RETAINER & SCREW ASSEMBLY	1
9	0010031	HUB CAP	1
10	0010574	UPPER SHAFT & BEARING ASSEMBLY	1
11B	0014040	B14 UPPER WHEEL	1
12B	0014038	B14 UPPER WHEEL & SHAFT ASSEMBLY	1

# BUTCHER BOY B14 UPPER WHEEL & HANGER ASSEMBLY

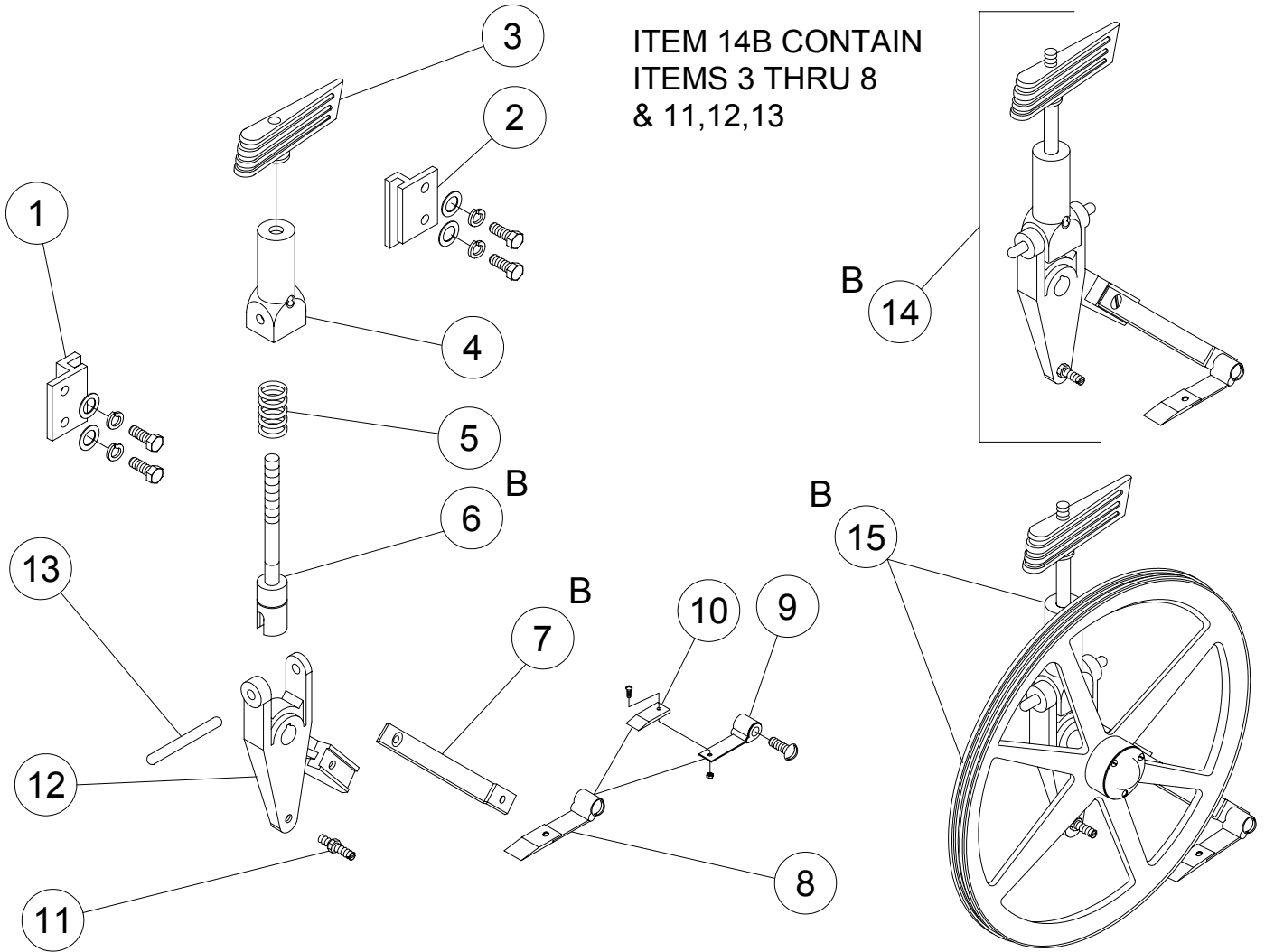

ITEM	PART#	DESCRIPTION	USE
1	0010282	GUIDE BLOCK	1
2	0010283	GUIDE BLOCK	1
3	0010141	TENSION HANDLE	1
4	0010278	GAUGE HOUSING	1
5	0010082	TENSION SPRING	1
6B	0014044S	ROD AND INDICATOR – B14	1
7B	0014043S	SCRAPER ARM – B14	1
8	0010377	SCRAPER SPRING ASSY	1
9	0010277	SCRAPER SPRING	1
10	0010040	FIBER SCRAPER	1
11	0010216	ADJ. SCREW	1
12	0010280	WHEEL HANGER	1
13	0010120	TENSION GAUGE PIN	1
14B	0014029	BLADE TENSION ASSY – B14	1
15B	0014205	UPPER WHEEL & HANGER ASSY – B14	1

# BUTCHER BOY B14 LOWER WHEEL ASSEMBLY

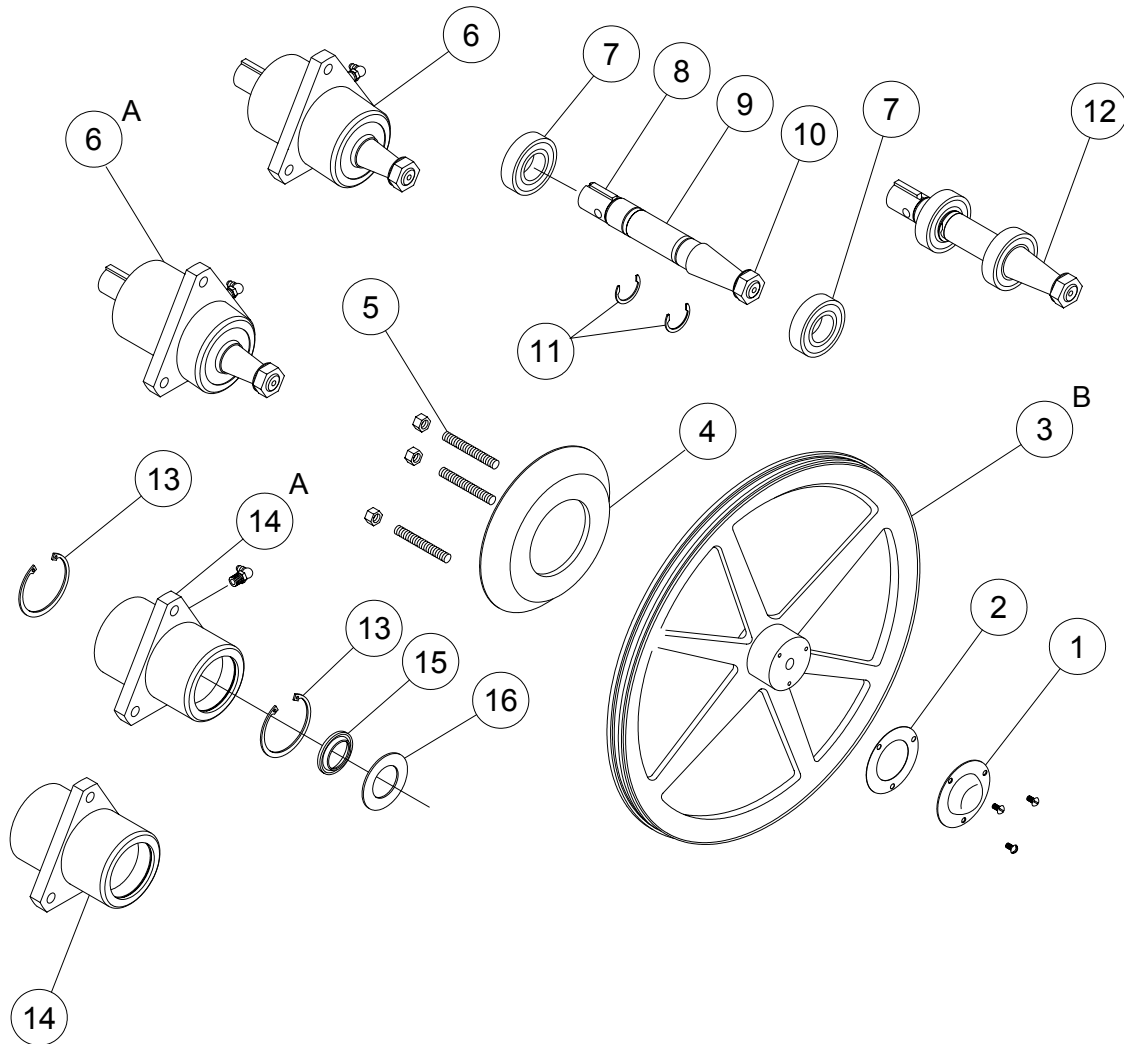

ITEM	PART#	DESCRIPTION	USE
1	0010031	HUB CAP	1
2	0010127	GASKET	1
3B	0014041	LOWER WHEEL - B14	1
4	0010077	BEARING HOUSING SUPPORT	1
5	0010078	STUD	3
6	0010087	LOWER SHAFT & HOUSING ASSY O/S	1
6A	0010025	LOWER SHAFT & HOUSING ASSY	*
7	0090300	BEARING	2
8	0059247-8	KEY SHAFT	1
9	0010023	SHAFT ASSY W/ WASHER & NUT	1
10	0010770	NUT & WASHER FOR SHAFT	1
11	0090201	RETAINING RING (SMALL)	2
12	0010575	LOWER SHAFT & BEARING ASSY	1
13	0090200	RETAINING RING (LARGE)	2
14	0010088	BEARING HOUSING O/S	2
14A	0010024	BEARING HOUSING	*
15	0090400	RUBBER SEAL	1
16	0010029	SPECIAL WASHER	1

# BUTCHER BOY B14 FRONT SCRAPER ASSEMBLY

**NEW STYLE**

B14 S/N 4-7775 - ON

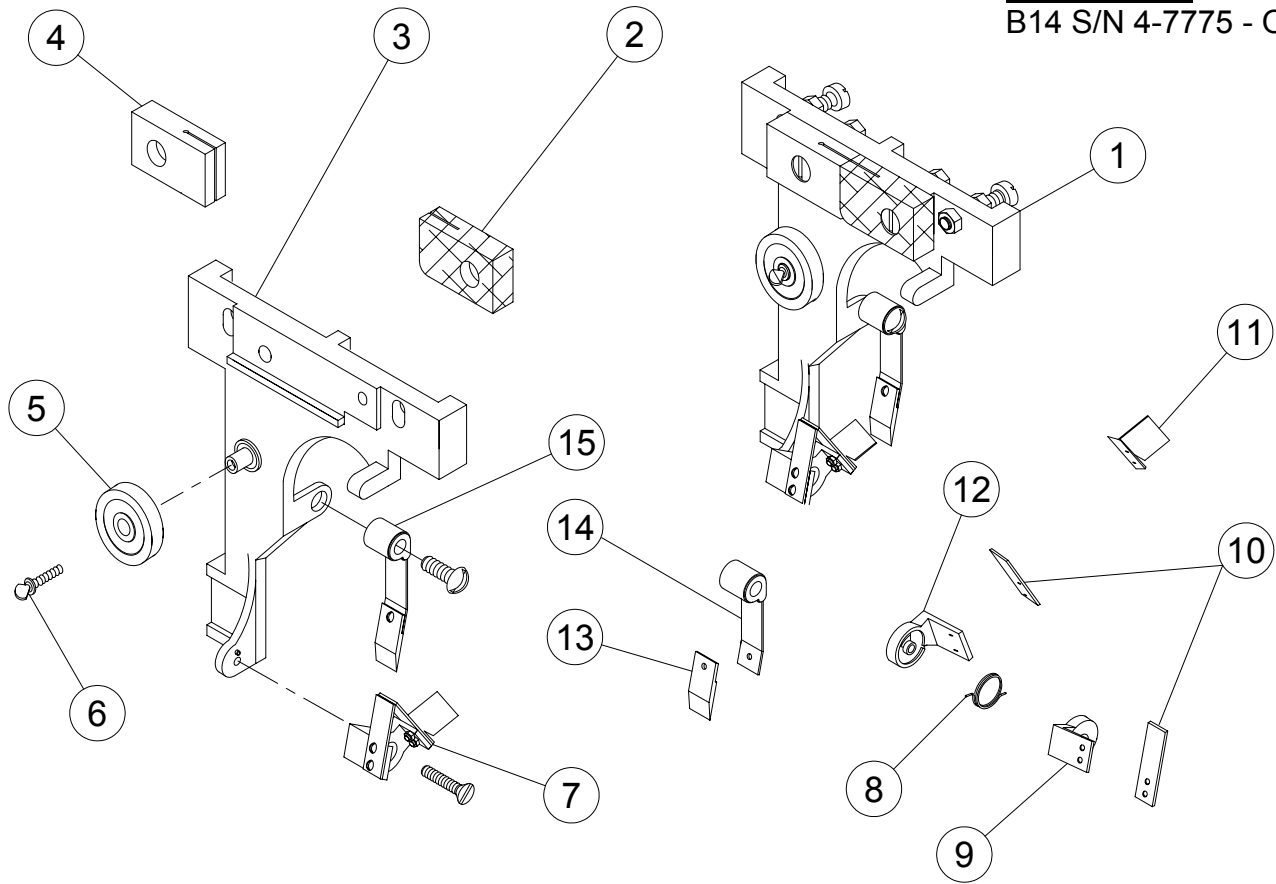

ITEM	PART#	DESCRIPTION	USE
1	0010304	FRONT SCRAPER ASSEMBLY	1
2	0010000	FIBER BLADE BLOCK	1
	0010000P	PLASTIC BLADE BLOCK	1
3	0010305	SCRAPER & ROLLER MOUNT	1
4	0010002	LOWER BLADE GUIDE STD. (.30)	1
	0020785	LOWER CARD. BLADE GUIDE HS (.30)	*
	0010597	LOWER BLADE GUIDE (.018)	*
	0020786	LOWER CARD. BLADE GUIDE HS (.018)	*
5	0090301	BALL BEARING	1
6	0010369	THUMB SCREW	1
7	0010464	BLADE SCRAPER ASSEMBLY	1
8	0010199	SPRING	1
9	0010302	SCRAPER HOLDER	1
10	0010310	SCRAPER STAINLESS STEEL	2
11	0010197	DEFLECTOR	1
12	0010301	SCRAPER HOLDER	1
13	0010040	WHEEL FIBER SCRAPER	1
14	0010277	SCRAPER SPRING	1
15	0010377	SPRING & SCRAPER ASSEMBLY	1

# BUTCHER BOY B14 BAND SAW

## REAR BLADE SCRAPER

**NEW STYLE**

B14 S/N 4-7775 - ON

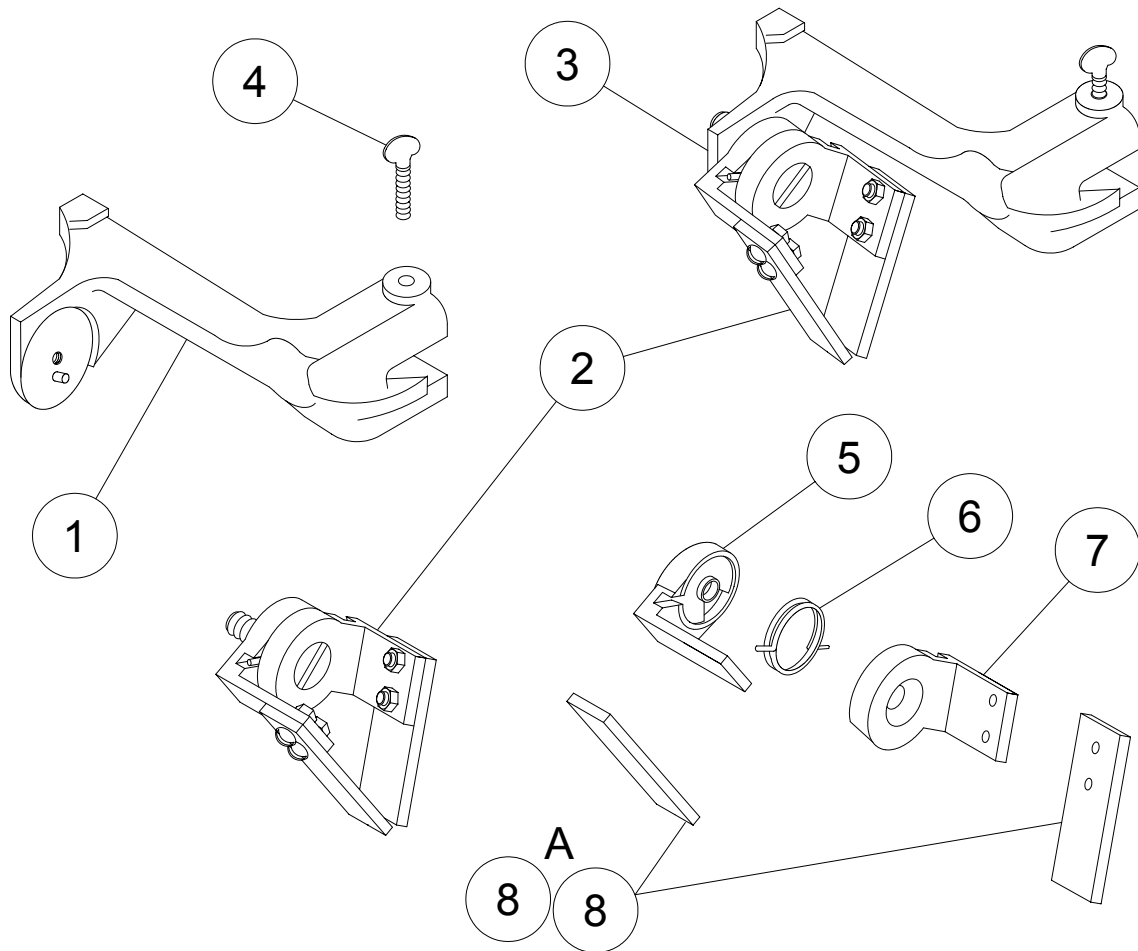

ITEM	PART#	DESCRIPTION	USE
1	0010246	SCRAPER MOUNT	1
2	0010460	BLADE FIBER SCRAPER ASSEMBLY	1
2B	0010464	BLADE S/S SCRAPER ASSEMBLY	1
3	0010298	REAR SCRAPER ASSEMBLY	1
4	0010303S	THUMB SCREW	1
5	0010302	SCRAPER HOLD	1
6	0010199	SPRING	1
7	0010301	SCRAPER HOLDER	1
8	0010300	FIBER SCRAPER	2
8A	0010310	S/S SCRAPER	2



# BUTCHER BOY B14 BAND SAW

## BAR GUIDE ASSEMBLY

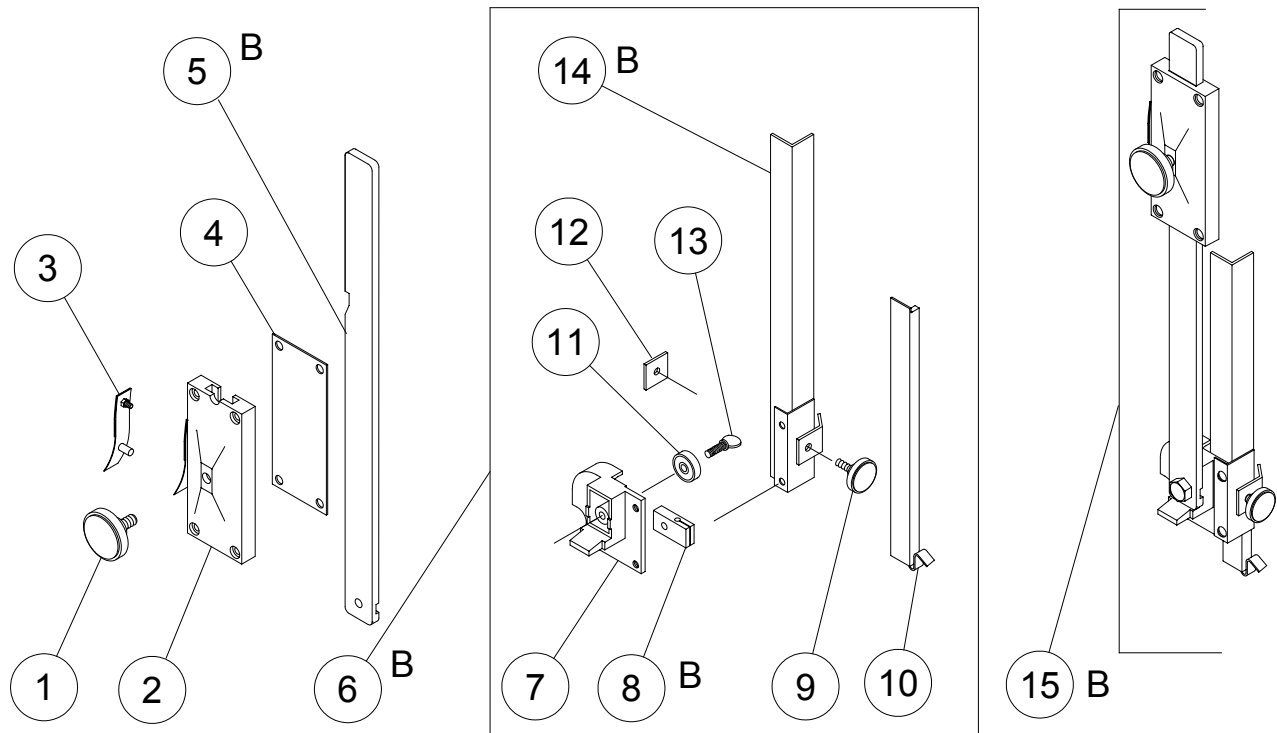

ITEM	PART#	DESCRIPTION	USE
1	0090600S	KNOB	1
2	0010266	ADJUSTABLE BAR GUIDE	1
3	0010273S	BAR RELEASE	1
4	0010373	GASKET ADJUSTING BAR GUIDE	1
5B	0014048S	ADJUSTABLE BAR B14	1
6B	0010716	BLADE GUARD ASSEMBLY B14	1
7	0010270	ADJUSTING BLADE GUIDE & ROLLER ASSEMBLY	1
8A	0010074	UPPER BLADE GUIDE (.030) BLADE	1
8B	0010356	UPPER BLADE GUIDE (.018) CARBIDE	1
8C	0010353	UPPER BLADE GUIDE (.030) CARBIDE	1
8D	0010079	UPPER BLADE GUIDE (.018)	1
9	0095084S	KNOB	1
10	0010712	GUARD EXTENSION	1
11	0090301	BACK UP BEARING	1
12	0010714	EXTENSION STOP	1
13	0010369	THUMB SCREW	1
14B	0014030	BLADE GUARD B14	1
15B	010371S	BAR GUIDE ASSEMBLY B14	1

# BUTCHER BOY B14 BAND SAW PARTS

## THICKNESS GAUGE ASSEMBLY

ITEM	PART#	DESCRIPTION	USE
1B	0014072	THICK GA. W/RATCHET & ROD B14	1
2	0010316	THICKNESS GAUGE ASSEMBLY	1
3B	0014341	GA. SLIDE ROD W/HD B14 S/S	1
4	0010180	RATCHET LOCK W/HARDWARE	1
5	0010297	ROLLER	1
6	0010250	GAUGE PLATE	1
7	0090700	BUSHING	2
8	0010284	GAUGE SPINDLE & ARM ASSY	1
9	0010313	GAUGE ARM SUPPORT	1
10	0010782S	LOCK PIN W/WASHER & NUT	1
11	0010315	KNOB	1
12	0010211	PIN	1
13	0010314S	SPRING	1
14	0010287	HAND WHEEL	1
15	0010291	HOUSING	1
16	0010208	RH SHORT CUT PLATE	1

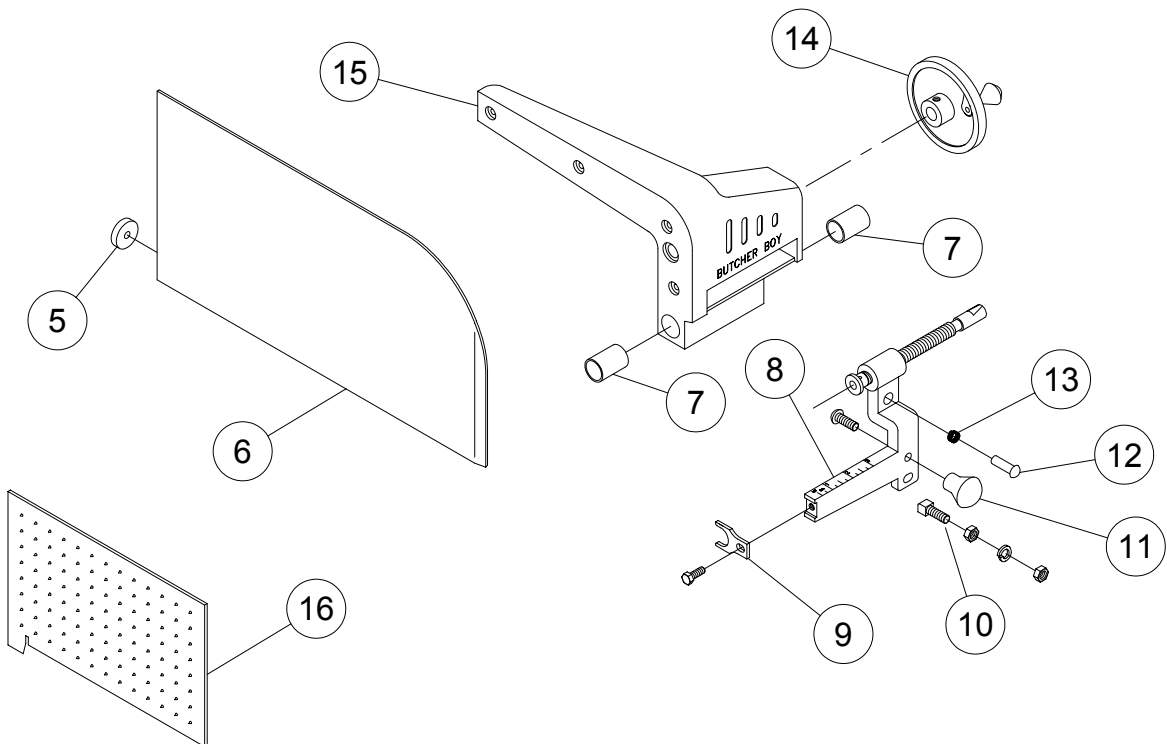
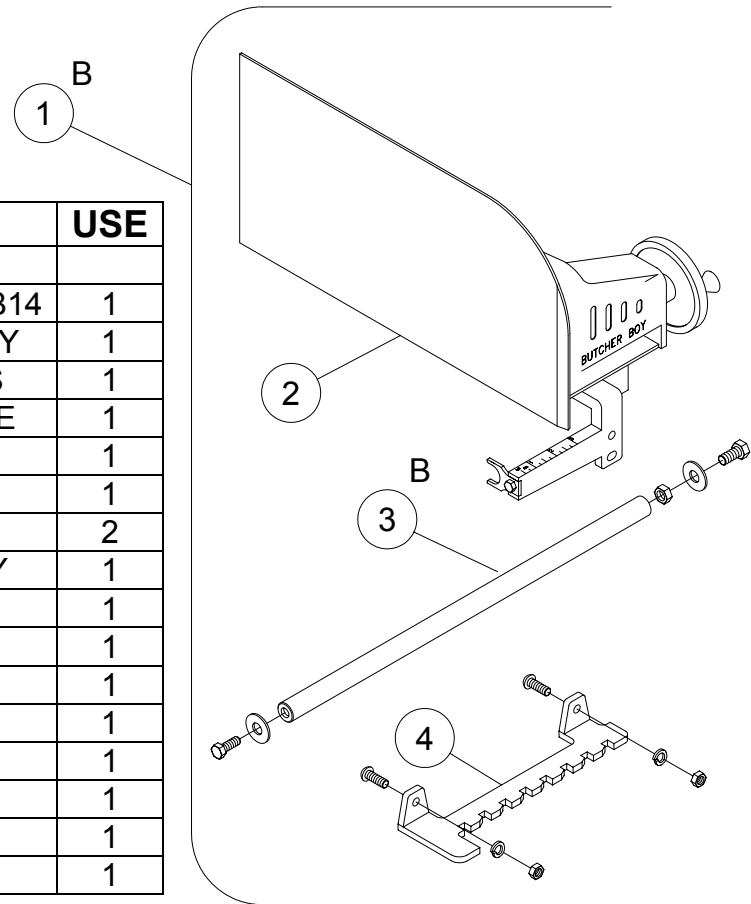

# BUTCHER BOY B14 BAND SAW PARTS

## TABLES & SUPPORT

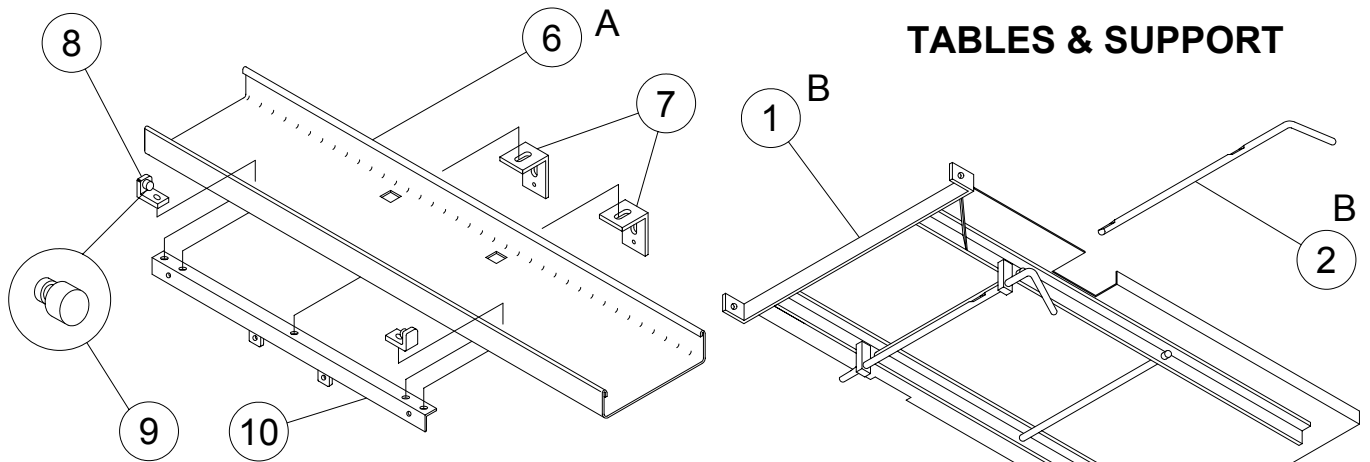

ITEM	PART#	DESCRIPTION	USE
1B	0014050S	STATIONARY TABLE ASSY B14	1
2B	0014060S	TABLE LOCK LEVER B14	1
3	0010331S	FRONT TABLE SUPPORT	1
4	0010332S	REAR TABLE SUPPORT	1
5	0010293	LEVER ADJUSTING LOCK	2
6A	0010375	TABLE TRACK B14	1
7	0010126S	TABLE TRACK SUPPORT	2
8	0010037S	STOP BRACKET ASSEMBLY	2
9	0090612	RUBBER STOP	2
10	0010294S	ANGLE SUPPORT ASSEMBLY	1
11	0010329S	TABLE WHEEL AXLE	2
12	0010098S	TABLE HOLDING PIN	3
13	0010303S	THUMB SCREW	1
14A	0010064	V-GROOVE WHEEL	4
14B	0010065	FLAT WHEEL	4
14C	0010068	U-GROOVE WHEEL	4
15	0010016	TABLE BUTTON	6
16A	0010319S	ROLLER TABLE ASSEMBLY B14	1
17	0010003	EXTENSION TABLE (OPT)	1

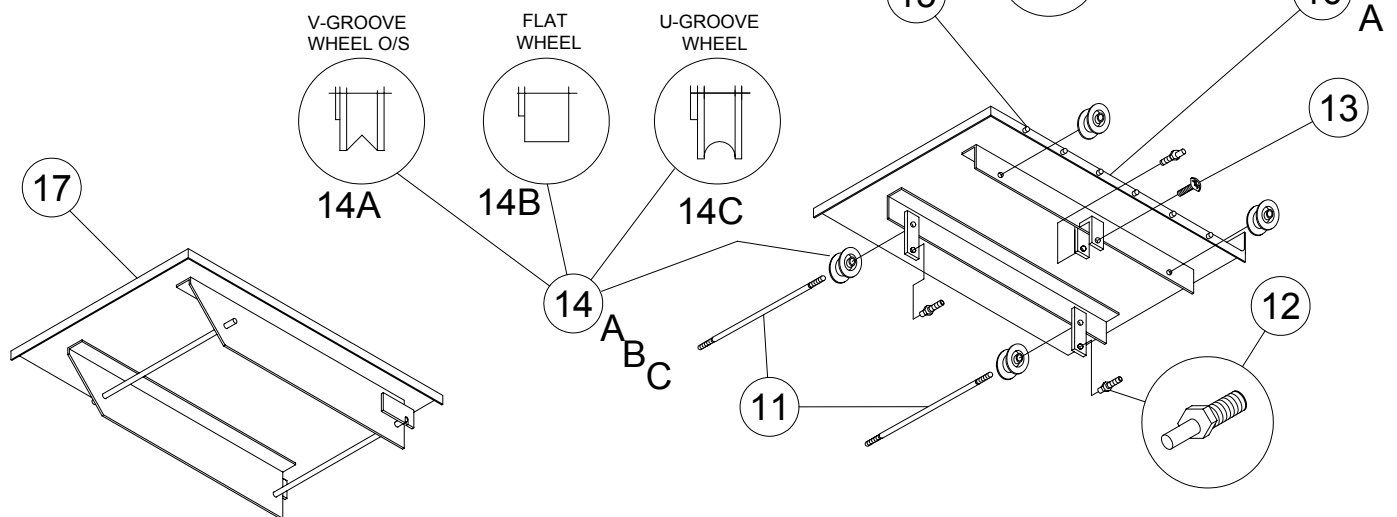

# BUTCHER BOY B14 BAND SAW

## MOTOR & DRIVE COMPONENTS

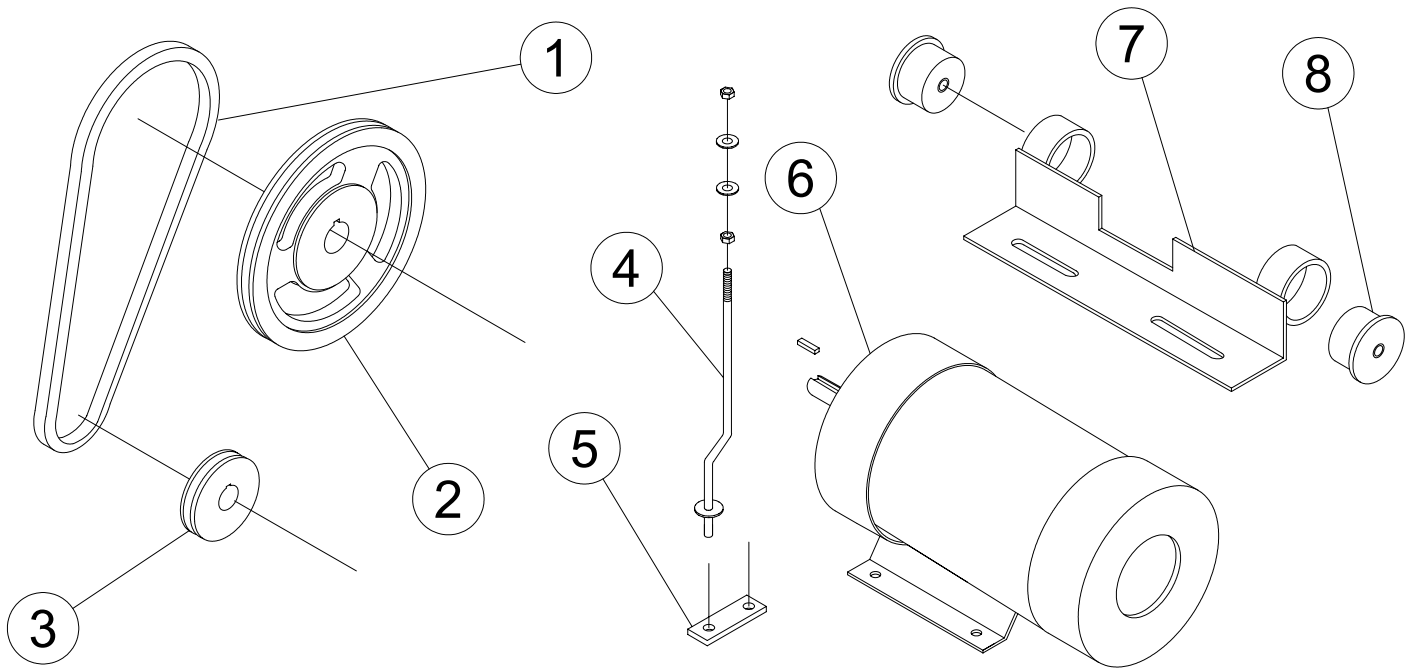

ITEM	PART#	DESCRIPTION	USE
		BELTS B14	
1	0090500	S/N PRIOR TO 4-15911	1
	0090518	S/N 15911 TO 4-16940	1
	0090538	S/N 4-16941 TO 4-21000	1
		DRIVEN PULLEY B14	
2	0010488	S/N PRIOR TO 4-15910	1
	0090199-002	S/N 4-15911 TO 4-16470	1
	0090199-001	S/N 4-16471 TO 4-16940	1
	0010876	S/N 4-16941 TO 4-21000	1
		DRIVEN PULLEY (MOTOR) B14	
3	0010485	S/N PRIOR TO 4-15910	1
	0090199-009	(7/8 BORE) S/N 4-15911 TO 4-16940	1
	0090199-098	(1-1/8 BORE) S/N 4-15911 TO 4-16940	1
	0010487	(7/8 BORE) S/N 4-16941 TO 4-21000	1
	0090199-056	(1-1/8 BORE) S/N 4-16941 TO 4-21000	1
4	0010384S	S/S TORQUE ROD ASSEMBLY / HARDWARE	1
5	0010430S	S/S TORQUE BRACKET	1
6	AS REQ.	MOTOR	1
7	0010344S	S/S MOTOR MOUNT ASSEMBLY	1
8	0010118	RUBBER MOUNT ASSEMBLY	2

# BUTCHER BOY B14 BAND SAW

## B14 SAW STD SPEED

0010605 WITH FIBER 0010000

SPARE PART KIT-.022-.025 BLADE 0010605P WITH PLASTIC 0010000P

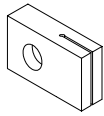

LOWER BLADE GUIDE  
PART# 0010002  
(1 PC)

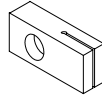

UPPER BLADE GUIDE  
PART# 0010074  
(1 PC)

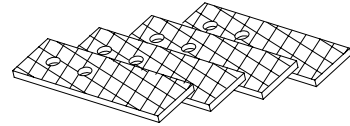

FIBER BLADE SCRAPERS  
PART# 0010300 (4 PCS)

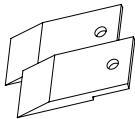

WHEEL FIBER SCRAPER  
PART# 0010040 (2 PCS)



RUBBER BUMPERS  
PART# 0090612 (2 PCS)

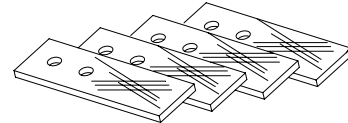

STAINLESS STEEL  
BLADE SCRAPERS  
PART# 0010310 (4 PCS)



BACK UP BEARING  
THUMB SCREW  
PART# 0010369S (2 PCS)

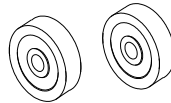

BACK UP BEARING  
PART# 0090301  
(2 PCS)

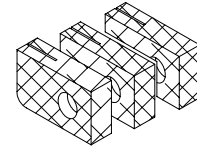

PLASTIC BLADE BLOCK  
PART# 0010000P (3 PCS)

## B14 SAW HI SPEED

0010940 WITH FIBER 0010000

SPARE KIT-.014-.018 BLADE 0010940P WITH PLASTIC 0010000P

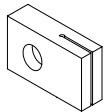

LOWER BLADE GUIDE  
WITH CARBOLITE PIN  
PART# 0020786  
(1 PC)

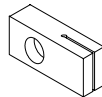

UPPER BLADE GUIDE  
WITH CARBOLITE PIN  
PART# 0010356  
(1 PC)

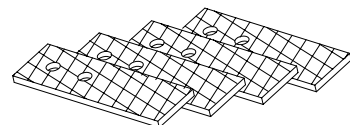

FIBER BLADE SCRAPERS  
PART# 0010300 (4 PCS)

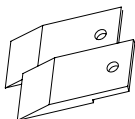

WHEEL FIBER SCRAPER  
PART# 0010040 (2 PCS)



RUBBER BUMPERS  
PART# 0090612 (2 PCS)

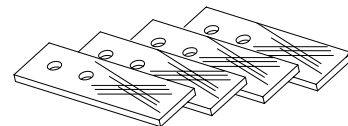

STAINLESS STEEL  
BLADE SCRAPERS  
PART# 0010310 (4 PCS)

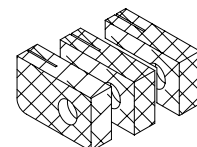

PLASTIC BLADE BLOCK  
PART# 0010000P (3 PCS)

# BUTCHER BOY B14 BAND SAW

## BUTCHER BOY B14 BAND SAW SWITCHES

## SWITCHES

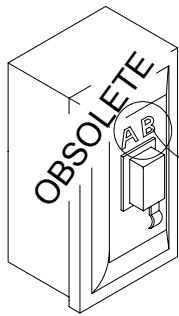

AB

B14 BEFORE S/N 4-15415

---

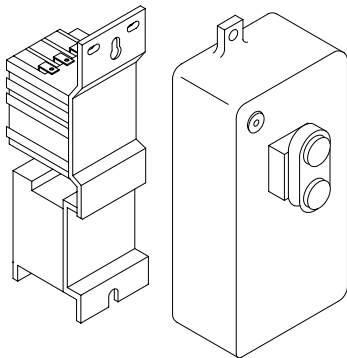

S01 P15

DEFINITE PURPOSE STARTER (MAG.) ASSY

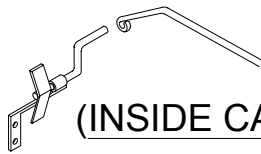

(INSIDE CABINET IN REAR)

B14 S/N 4-15451 TO S/N 4-19875

---

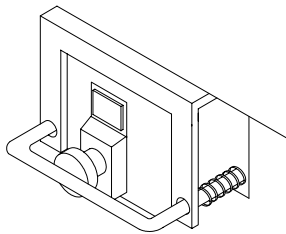

S02 P16

DEFINITE PURPOSE STARTER (MAG.) ASSY  
(ON FRONT OF MACHINE)

B14 S/N 4-19724 TO S/N 4-20406

---

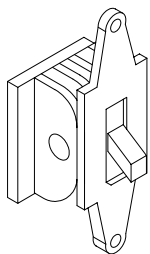

S03 & S04

P17

STANDARD SINGLE PHASE AND THREE PHASE  
MANUAL STARTER (TOGGLE) (INSIDE CABINET)

B14 S/N 4-10883 TO S/N 4-20800

---

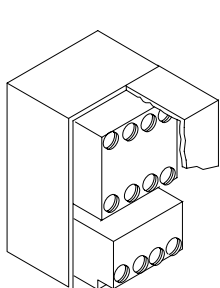

S05

P18

DEFINITE PURPOSE STARTER (MAG.) ASSY  
(INSIDE CABINET)

B14 S/N 4-20407 TO S/N 4-20800

# BUTCHER BOY B14 BAND SAW

**B14 DEFINITE PURPOSE STARTER (MAG.) ASSEMBLY  
(INSIDE CABINET IN REAR)**

**B14 S/N 4-15451 TO S/N 4-19875**

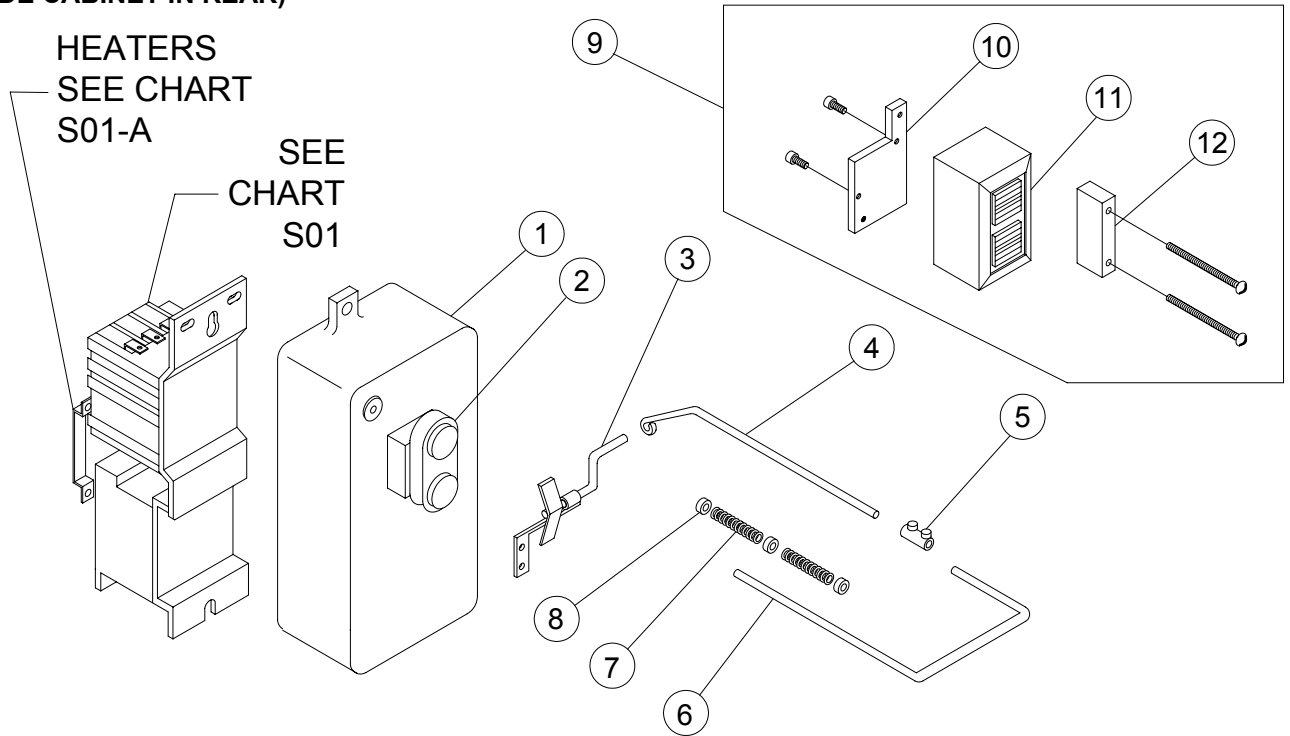

CHART S01							SWITCH PART #	HEATER	
VOLTAGE / AMPS								(2) 1PH H#	(3) 3PH PART#
	PH	5.75	460	230	208	115			
1 1/2 HP	3	1.9					0093033	E29	0093525
	3		2.6				0093008	E34	0093521
	3			5.2			0093007	E44	0093531
	3				5.8		0093007	E46	0093532
	1			10.			0093006	E51	0093536
	1					11.0	0093006	E52	0093541
	1						20.0	0093055	E61
2 HP	3	2.7					0093033	E34	0093521
	3		3.4				0093008	E38	0093528
	3			6.8			0093007	E48	0093534
	3				7.6		0093007	E50	0093556
	1			12.0			0093006	E53	0093537
	1					13.0	0093006	E54	0093538
	1						24.0	0093055	E67

ITEM#	PART#	DESCRIPTION	QTY.	ITEM#	PART#	DESCRIPTION	QTY.
1	0010192	SWITCH BOX	1	7	0010336S	S/S SPRING	2
2	NOT AVAILABLE SEE ITEM 9 FOR REPLACEMENT			8	0090606S	S/S COLLAR	3
3	0010610S	S/S ROCKER	1	9	0059370-BSAW	REPLACEMENT KIT FOR 0059370	1
4	0014125S	S/S ROD B14	1	10	0010930	MOUNTING PL	1
5	0010212S	S/S COUPLING	1	11	0093999-136	P/B SWITCH	1
6	0010244S	S/S HANDLE	1	12	0010931	SPACER	1

# BUTCHER BOY B14 BAND SAW PARTS

## B14 DEFINITE PURPOSE START (MAG.) ASSEMBLY (ON FRONT OF SAW)

B14 S/N 4-19724 TO S/N 4-20406

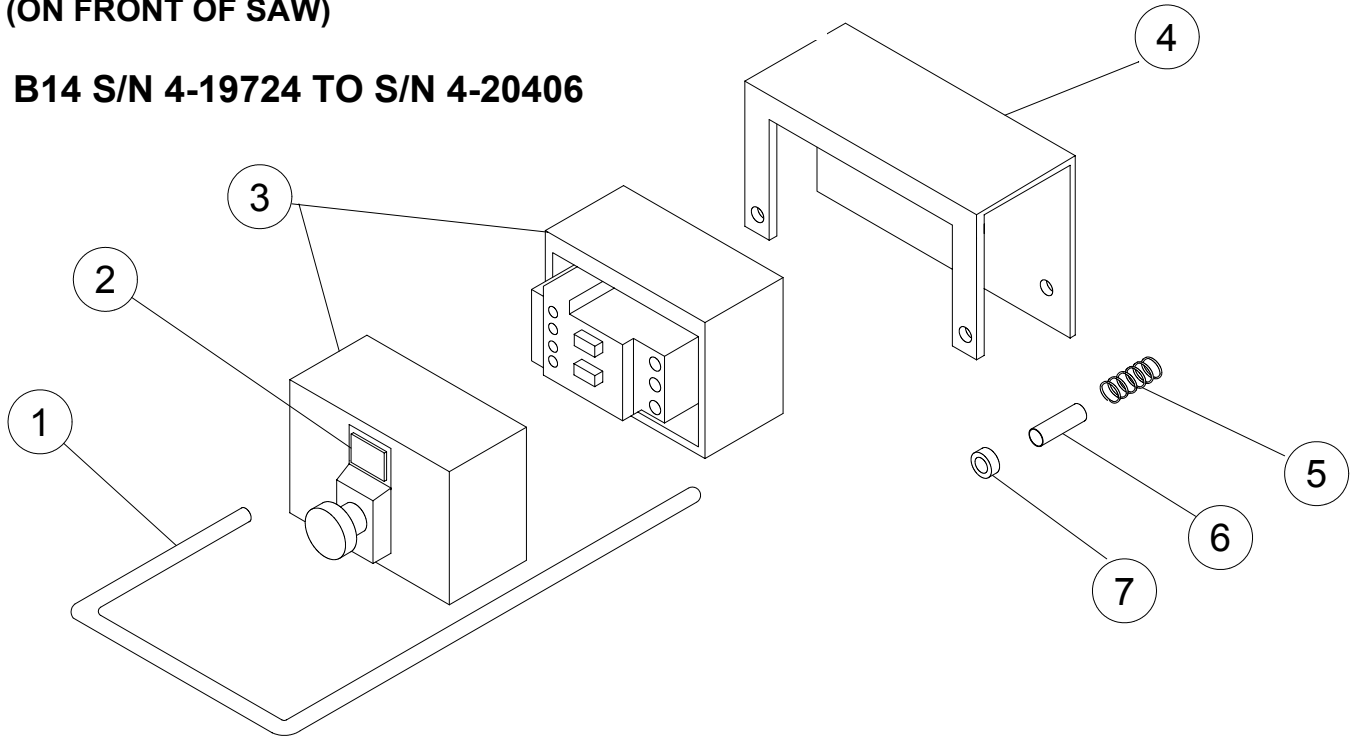

CHART S02								
		VOLTAGE / AMPS				STARTER IN ENCLOSURE		
	PH	575	460	230	205	115		
1 1/2 HP	3	1.9					0093926	
	3		2.6				0093930	
	3			5.2			0093933	
	3				5.8		0093933	
	1			10.0			0093934	
	1					11.0		0093934
	1						2.0	0093942
2 HP	3	2.7					0093927	
	3		3.4				0093930	
	3			6.8			0093934	
	3				7.6		0093934	
	1			12.0			0093935	
	1					13.0		0093935
	1						24.0	0093943

ITEM#	PART#	DESCRIPTION	QTY.
1	0010846	S/S STOP BAR	1
2	*0093999-094	SEAL KIT	1
3	SEE CHART S02	CONTACTOR & ENCLOSURE	1
4	0010850S	S/S FRONT BRACKET	1
5	0010802	S/S SPRING	1
6	0010803	S/S TUBING	1
7	0090606S	S/S COLLAR	1



# BUTCHER BOY B14 BAND SAW

## S03 B14 STD MANUAL STARTER REAR MOUNTED (INSIDE CABINET) S/N 4-10883 TO S/N 4-20406

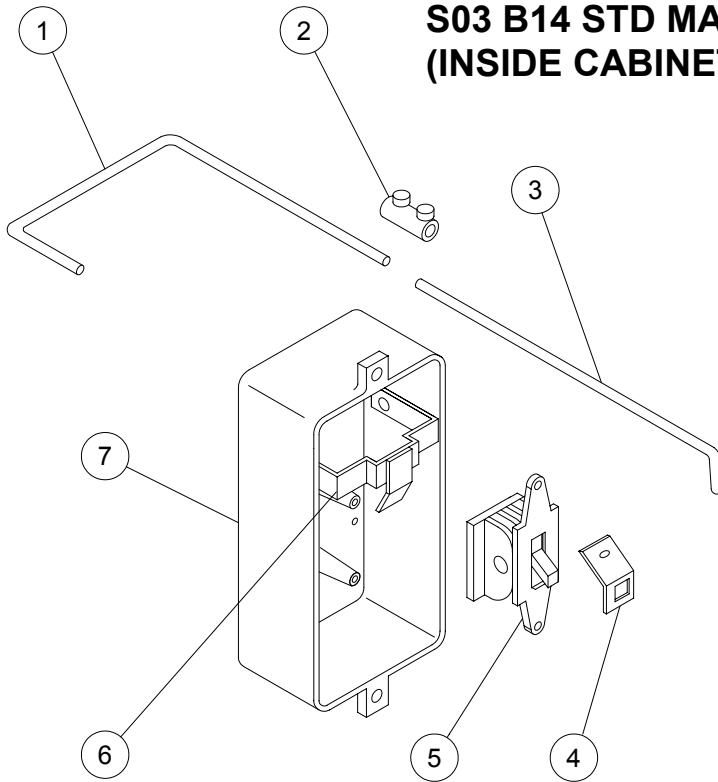

ITEM#	PART#	DESCRIPTION	QTY.
1	0010244S	S/S HANDLE	1
2	0010212S	S/S COUPLING	1
3	0010224S	S/S ROD B14	1
4	0010242S	S/S LEVER	1
5	0093020	1 PH SWITCH	1
5	0093021	3 PH SWITCH	1
6	0010228	S/S LEVER ASSY	1
7	0010338	SWITCH BOX W/ #6	1

## S04 B14 STD MANUAL STARTER FRONT MOUNTED (INSIDE CABINET) S/N 4-20407 TO S/N 4-20800

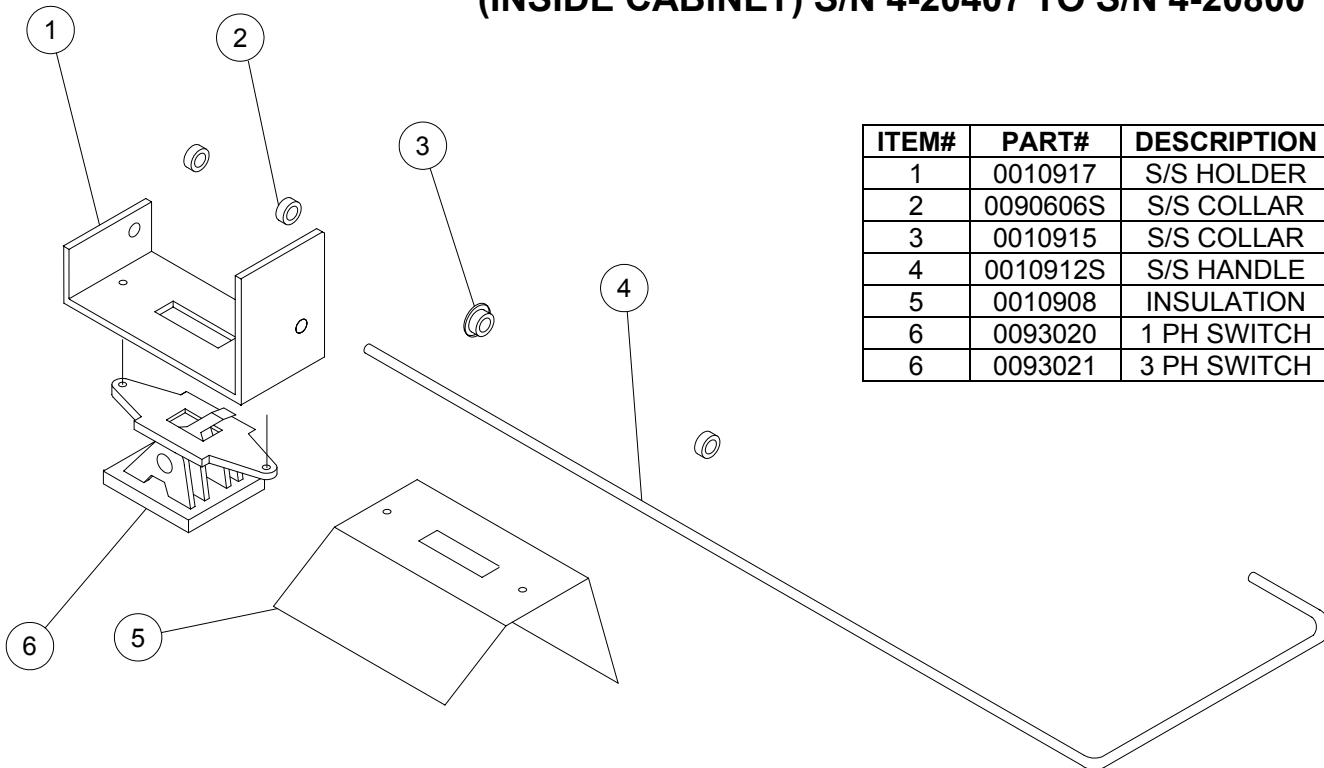

ITEM#	PART#	DESCRIPTION	QTY.
1	0010917	S/S HOLDER	1
2	0090606S	S/S COLLAR	1
3	0010915	S/S COLLAR	1
4	0010912S	S/S HANDLE	1
5	0010908	INSULATION	1
6	0093020	1 PH SWITCH	1
6	0093021	3 PH SWITCH	1

# BUTCHER BOY B14 BAND SAW PARTS

S05 B14 DEFINITE PURPOSE START (MAG.)  
ASSEMBLY (INSIDE CABINET)

B14 S/N 4-20407 TO S/N 4-20800

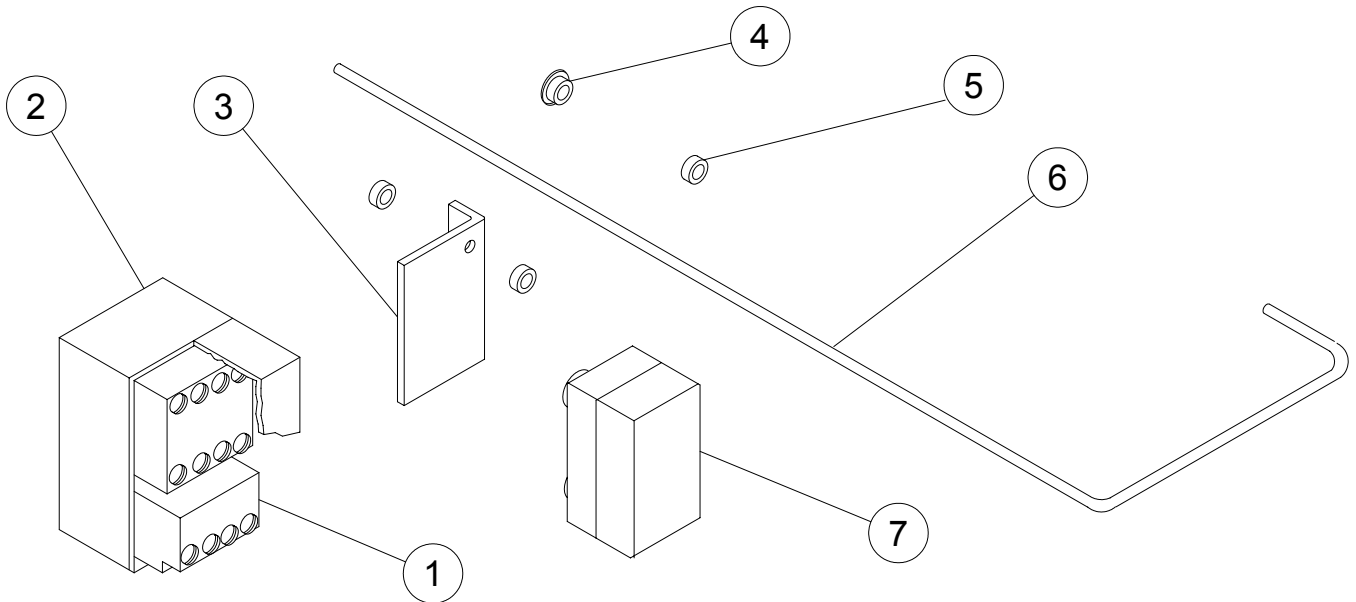

ITEM#	PART#	DESCRIPTION	QTY.
1	SEE CHART S05	CONTACTOR & OVERLOAD	1
2	0010913	ENCLOSURE	1
3	0010911S	S/S ROCKER	1
4	0010915	S/S COLLAR	1
5	0090606S	S/S COLLAR	1
6	0010912S	S/S HANDLE	1
7	0093279	P/B SWITCH	1

CHART S05							
	PH	VOLTAGE / AMPS					CONTACTOR & OVERLOAD
		575	460	230	208	115	
1 1/2 HP	3	1.9					
	3		2.6				0093452
	3			5.2			0093458 (SP)
	3				5.8		0093458 (SP)
	1			10.0			0093462
	1				11.0		0093462
	1					20.0	0093461
2 HP	3	2.7					0093466
	3		3.4				0093463
	3			6.8			0093458 (SP)
	3				7.6		0093458 (SP)
	1			12.0			0093459
	1				13.0		0093459
	1					24.0	0093464

# BUTCHER BOY B14 BAND SAW PARTS

**WARNING:**  
NEVER TIGHTEN BLADE BEYOND RED INDICATOR LINE.  
BLADE BREAKAGE, SHORTEN BEARING LIFE AND SHAFT BREAKAGE MAY OCCUR

IF SAW BLADE IS JUMPING THE FOLLOWING ADJUSTMENT SHOULD BE MADE.

ADJUST UPPER WHEEL BY:

1. COMPLETELY RELEASING TENSION ON SAW BLADE BY LOOSENING TENSION HANDLE.
2. LOOSENING LOCK-NUT AND TURNING ADJUSTING SCREW ONE OR TWO TURNS IN A CLOCKWISE DIRECTION AND THEN TIGHTENING LOCK-NUT. THIS ADJUSTMENT WILL BRING BLADE AGAINST SHOULDER OF WHEEL.

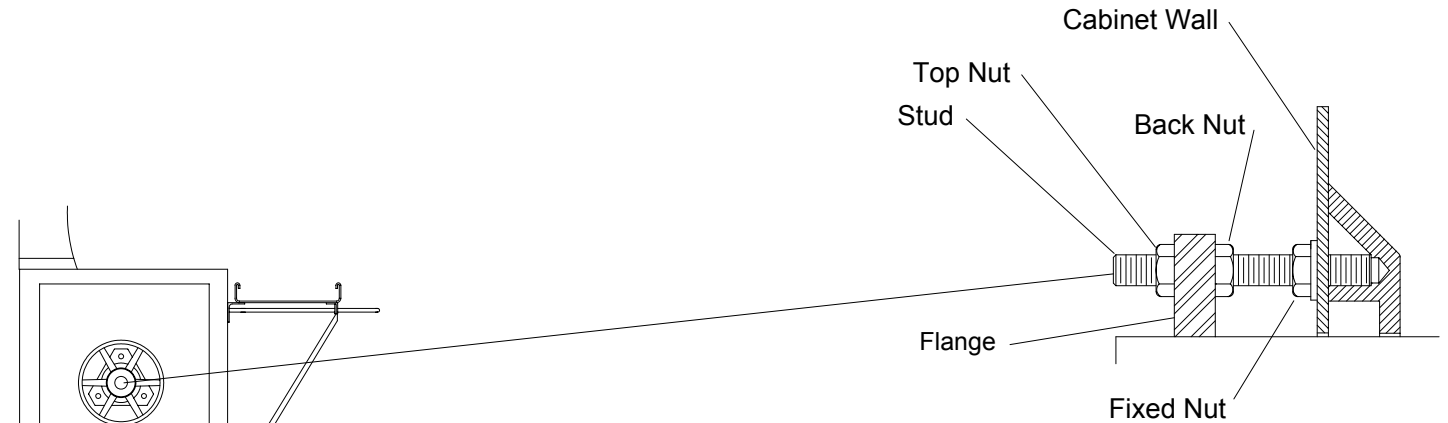
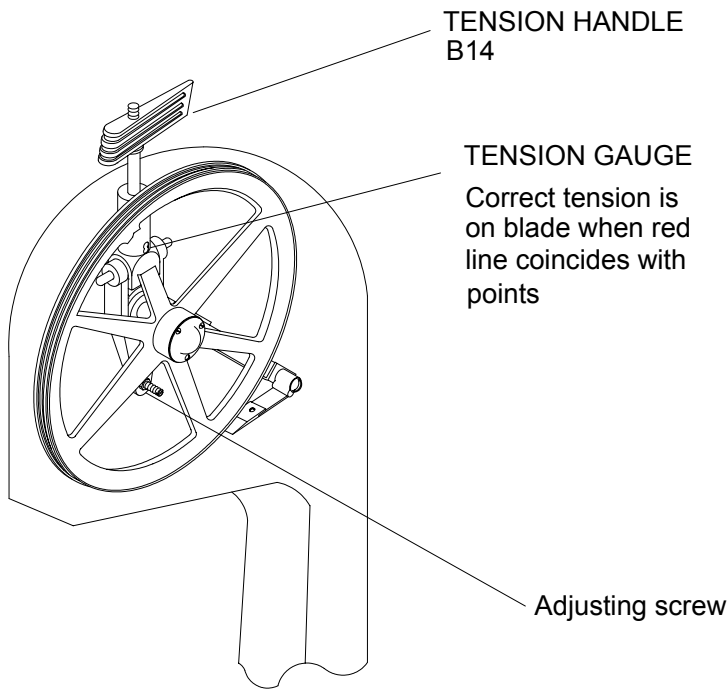

ADJUST CAMBER OF LOWER WHEEL BY:

1. COMPLETELY RELEASE TENSION ON SAW BLADE BY LOOSENING THE TENSION HANDLE. (SEE ABOVE)
2. LOOSEN TOP NUT IN FRONT OF FLANGE, THEN TURN NUT IN BACK OF FLANGE CLOCKWISE 1/2 TURN. TIGHTEN TOP NUT. REPEAT THIS PROCEDURE AS MANY TIME AS NECESSARY. WHEN FINISHED, TIGHTEN TOP NUT SECURELY.

**\*IMPORTANT: NEVER LOOSEN FIXED NUTS FOR ADJUSTMENT.**

# BUTCHER BOY B14 BAND SAW PARTS LUBRICATION INSTRUCTIONS

UPPER  
WHEEL;  
2 to 4  
strokes with  
grease gun  
every 30  
days, as  
needed

TENSION  
HANDLE:  
lubricate daily  
with edible oil  
while  
screwing  
in and out

UPPER BLADE  
GUIDE SUPPORT  
BAR:  
lubricate daily with  
food grade oil while  
moving up and down

THICKNESS  
GAUGE  
THREADS:  
lubricate daily  
with edible oil  
while screwing  
in and out

MEAT  
CARRYING  
TABLE  
WHEEL(4)  
lubricate daily  
with edible oil

THICKNESS  
GAUGE SLIDE  
ROD:  
lubricate daily  
with edible oil  
while  
sliding full  
length.

LOWER WHEEL  
BEARING  
HOUSING:  
2 to 4 strokes with  
grease gun every  
30 days as needed

MOTOR:  
if equipped with  
grease fittings  
grease every six  
months with  
bearing grease

AFTER WASHING AND SANITIZING SPRAY ENTIRE SAW  
(INTERIOR AND EXTERIOR) WITH FOOD GRADE WHITE OIL.