

BUTCHER BOY A42 FLOOR GRINDER

OPERATING INSTRUCTIONS AND PARTS MANUAL

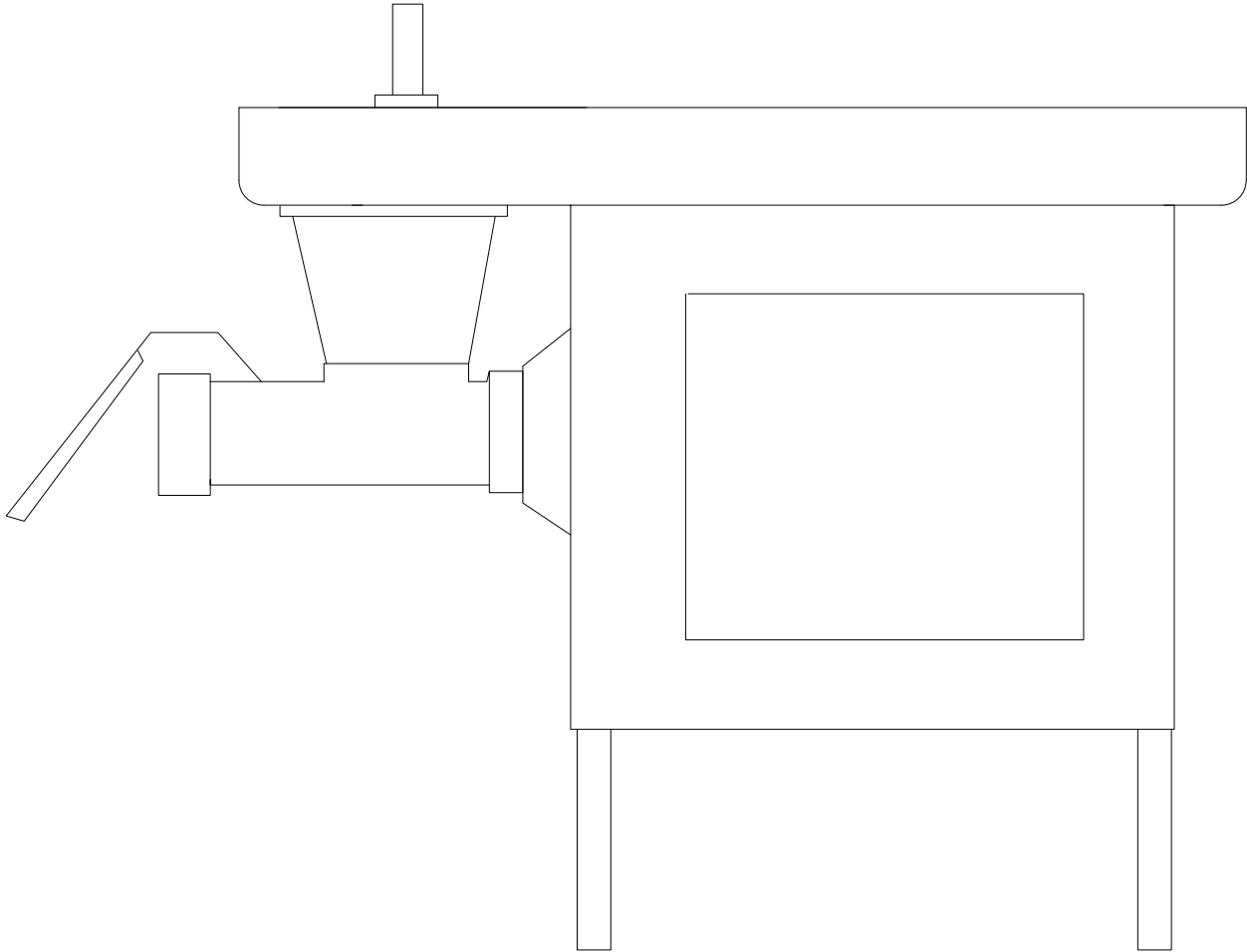

MANUFACTURED BY:

AMERICAN MEAT EQUIPMENT LLC.

640 MULLBERRY AVE.

SELMER, TN 38375

PH: 1-731-434-1012 • FAX 1-731-645-6056

BUTCHER BOY A42 FLOOR GRINDER

CUTTING GROUP & COMPONENTS

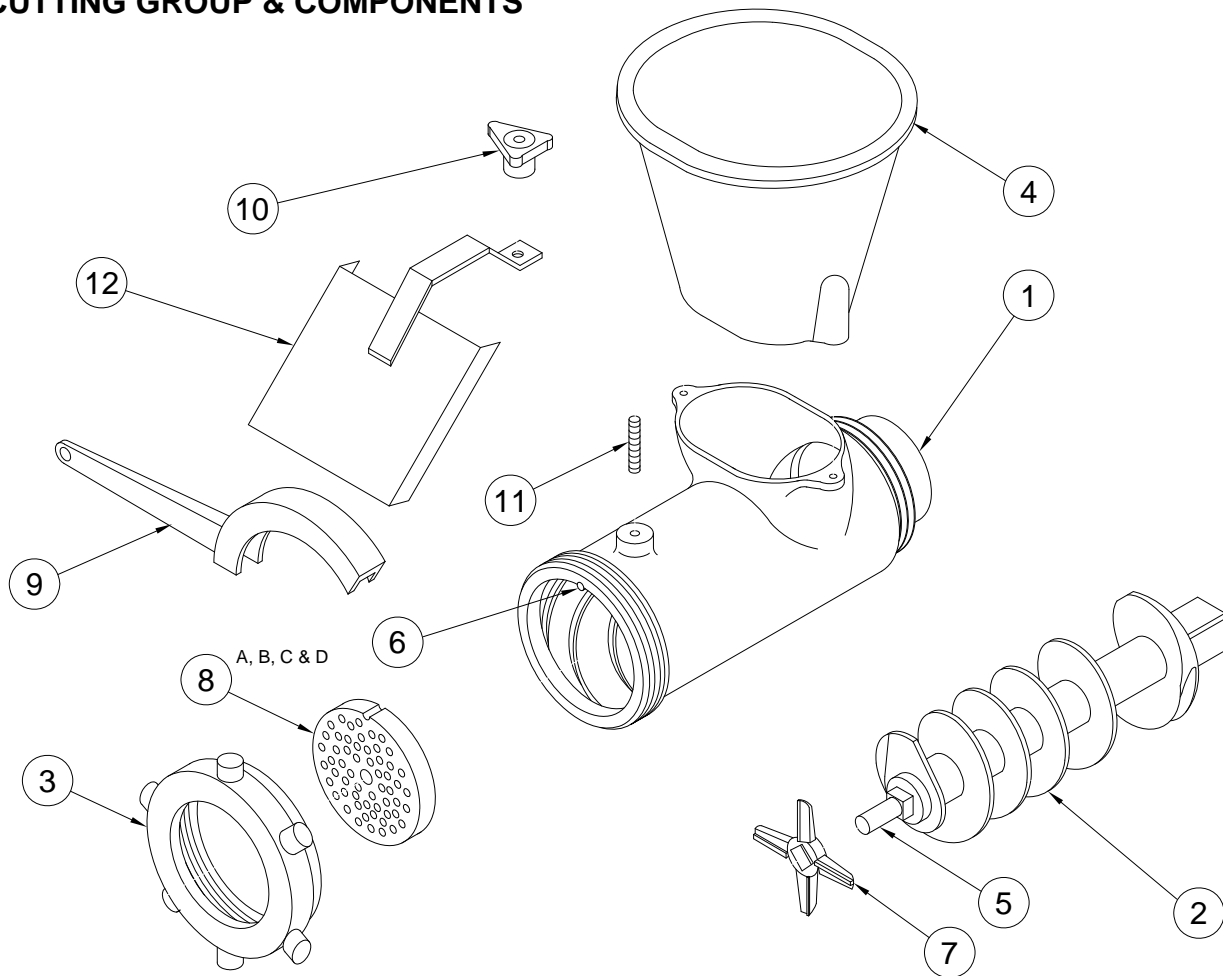

NO	PART#	DESCRIPTION	UOM
1	0042513	A42 STRAIGHT BOWL	1
2	0042542	FEED SCREW ASSEMBLY	1
3	0042516	A42 KNIFE & PLATE RING	1
4	0042514	BOWL EXTENSION	1
5	0021038	A42 FEED SCREW STUD	1
6	0059232	PIN PLATE HOLDER	1
7	0090925P	42 KNIFE (PREMIUM)	1
8A	0090921	42-1/8" HOLE PLATE	1
8B	0090922	42-3/16" HOLE PLATE	1
8C	0090920	42-1/4" HOLE PLATE	1
8D	0090923	42-3/8" HOLE PLATE	1
9	0059188	WRENCH	1
10	0059224	HAND WHEEL SPURT GUARD	1
11	0059223	STUD HAND WHEEL	1
12	0059208	SPURT GUARD	1

BUTCHER BOY A42 FLOOR GRINDER

PAN, CABINETS, COVERS & MIS.

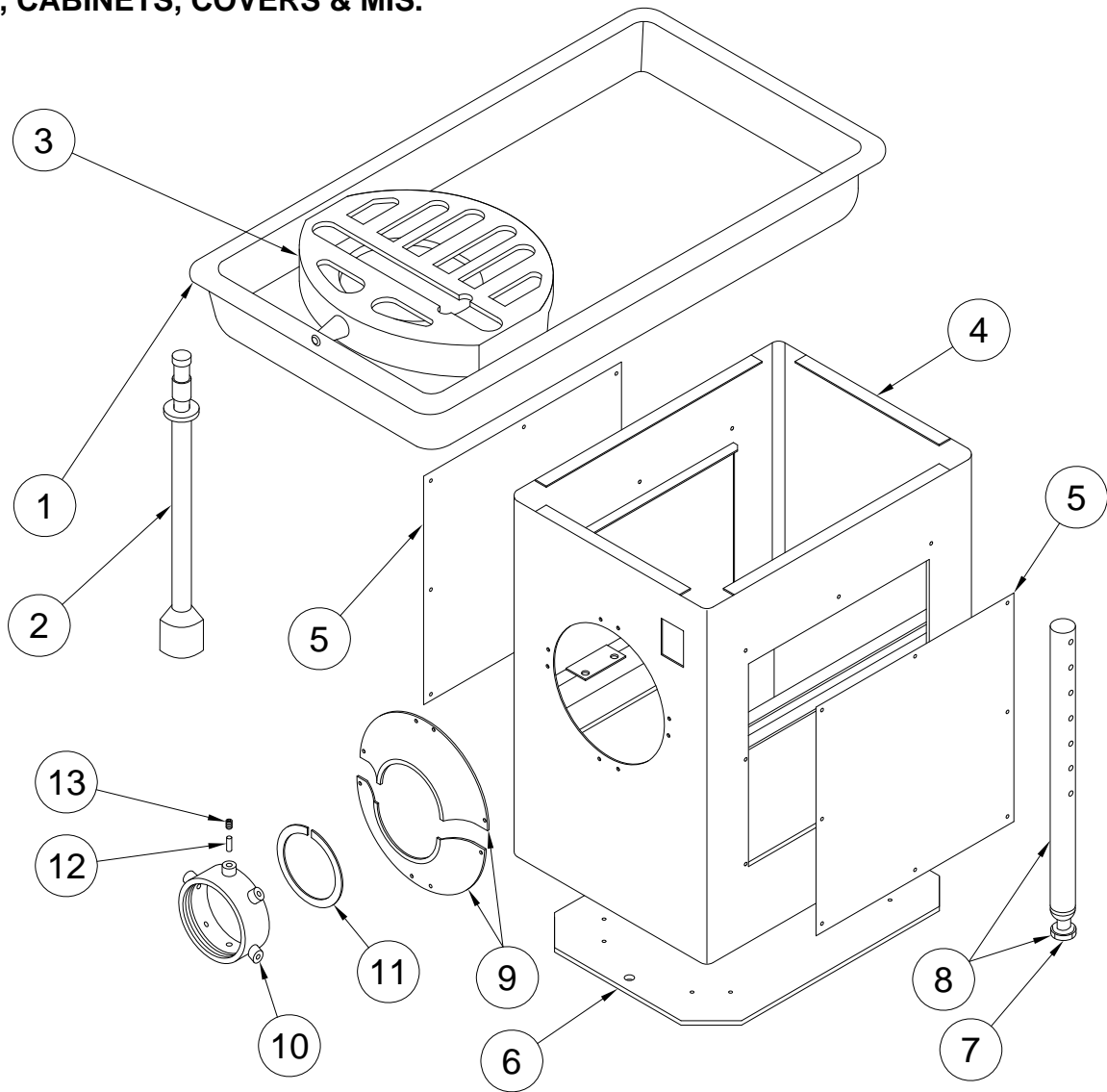

NO	PART#	DESCRIPTION	UOM	NO	PART#	DESCRIPTION	UOM
1	0059272	PAN	1	8	0059199S	SS LEG ASSEMBLY	4
2	0042518	A42 STOMPER	1	9	0059064	COVER RING	1
3	0053045	A42 GUARD	1	10	0059535	LOCKING RING	1
4	0059331	A42 & A52 CABINET	1	11	0059128	SNAP RING	1
5	0059143	SS SIDE COVER	2	12	DP-05-14-SS	PIN	6
6	0059177S	SS BOTTOM COVER	1	13	0095810	SCREW M10X1.5	6
7	0059390	FOOT ASSEMBLY	4				

BUTCHER BOY A42 FLOOR GRINDER

GEAR BOX ASSEMBLY 0059054 & COMPONENTS

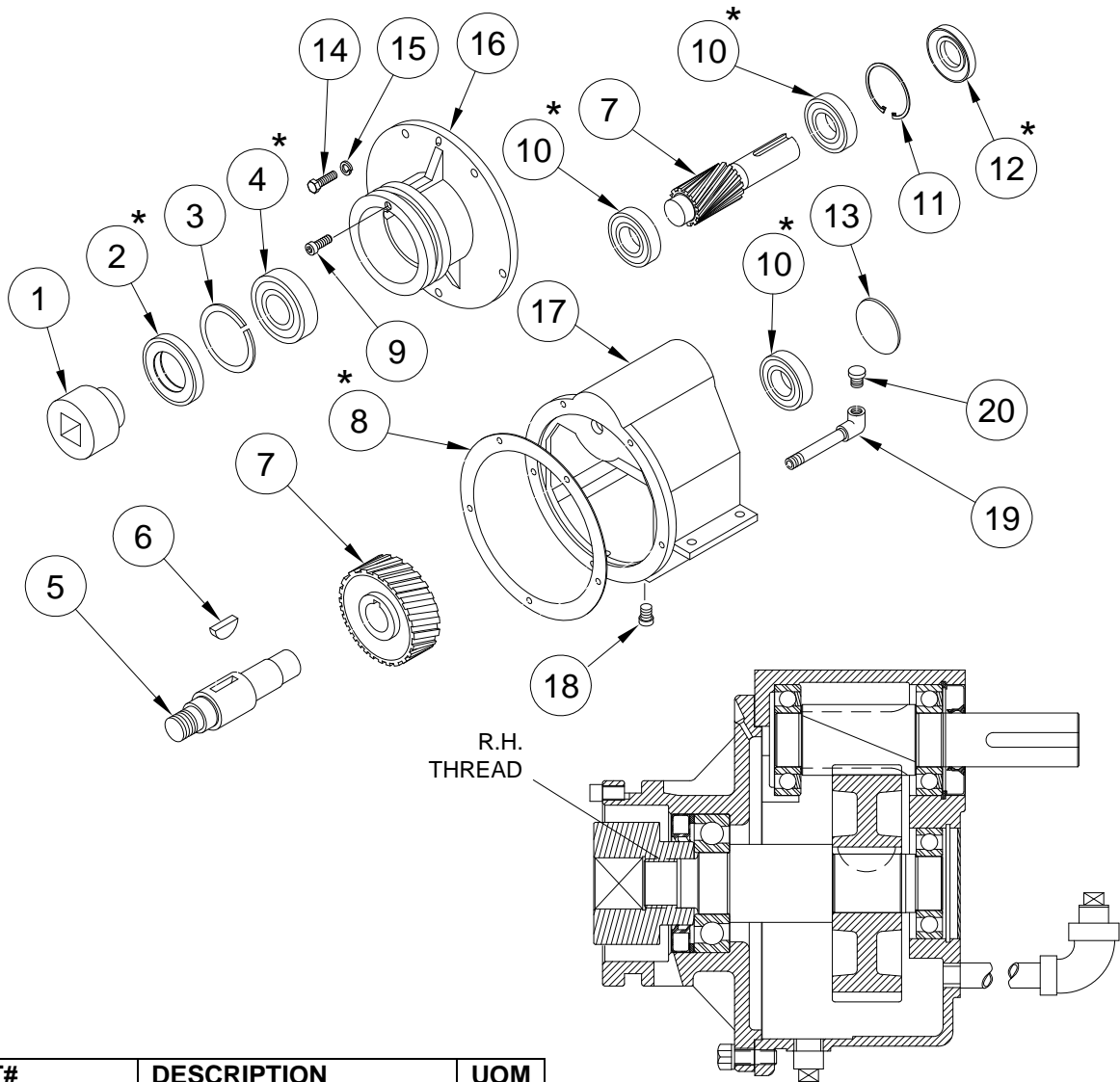

NO	PART#	DESCRIPTION	UOM
1	0059060	FEED SCREW CHUCK	1
2	*0090405	SEAL (LARGE)	1
3	0059157	SPACER	1
4	*0090303	THRUST BEARING	1
5	0059057	DRIVE SHAFT	1
6	0090607	WOODRUFF KEY	1
7	0059052	PINION & GEAR WHEEL	1
8	*0059061	GASKET	1
9	SHCS-23-08-SS	SOC. HD. CAP SCREW	1
10	*0090304	BALL BEARING	3
11	0090205	RETAINING RING	1
12	*0090404	SEAL (SMALL)	1
13	0059058	PLUG	1
14	HHCS-23-16-SS	HEX HD. CAP SCREW	5

ALL PARTS WITH * MAKE UP 0059050 REBUILD KIT

NO	PART#	DESCRIPTION	UOM
15	SLW-06-SS	LOCK WASHER	5
16	0059056	GEAR BOX COVER	1
17	0040012	GEAR HOUSING	1
18	0090613	PIPE PLUG	1
19	0059140	PIPE ASSEMBLY	1
20	0090610	BREATHER	1
21	0059050	REBUILD KIT*	

BUTCHER BOY A42 FLOOR GRINDER

DRIVE COMPONENTS

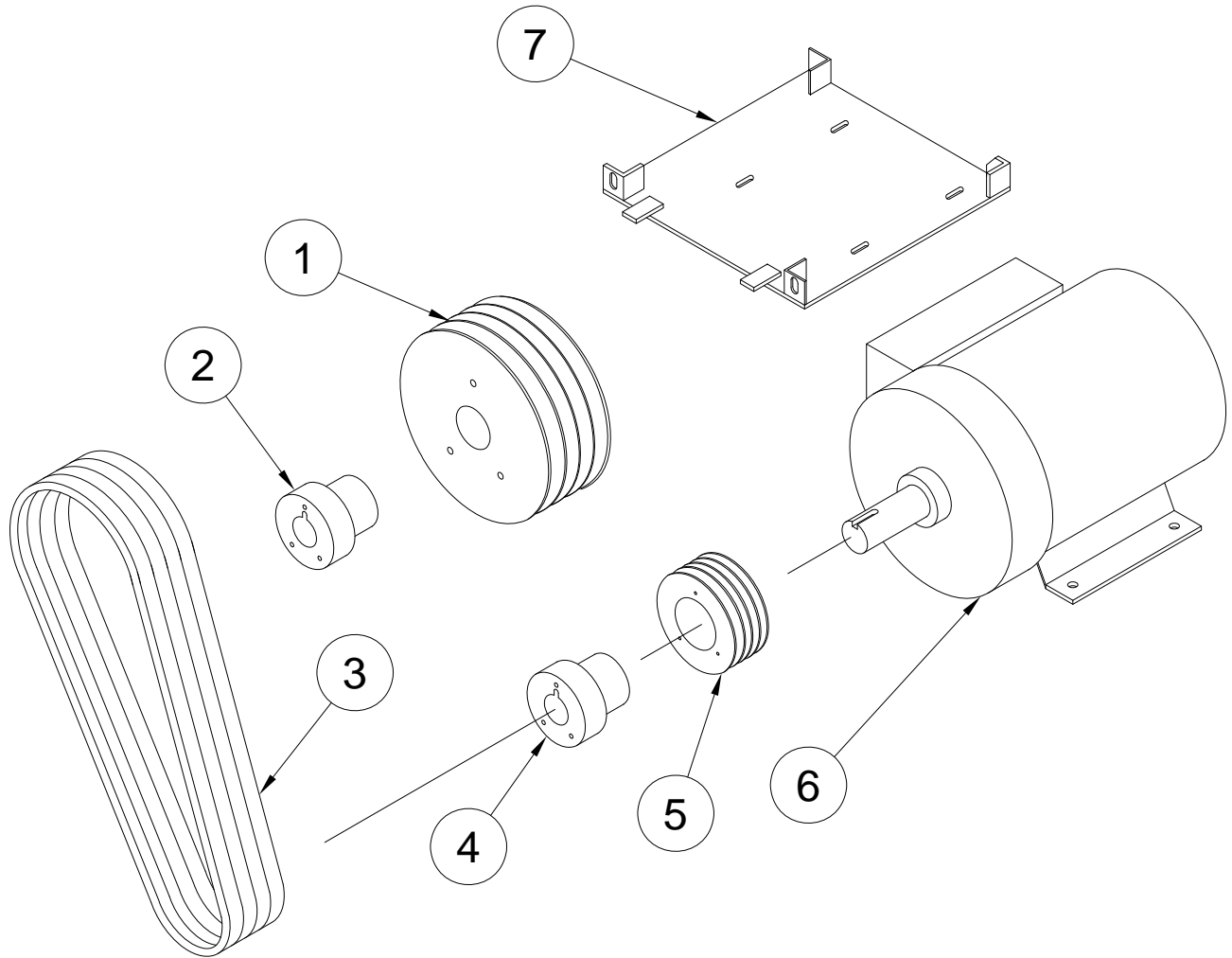

NO	PART#	DESCRIPTION	UOM
1	0090111	DRIVEN PULLEY 4GRV 7.5 HP	1
2	0090153	DRIVEN HUB	1
3	0090519	BELT	4
4	0090149	MOTOR HUB	1
5	0090108	MOTOR PULLEY 4GRV	1
6	0092202	MOTOR 5 HP, 230V 1PH	1
7	0043699	SS MOTOR MOUNT	1

BUTCHER BOY A42 FLOOR GRINDER

ELECTRICAL COMPONENTS

THIS PAGE FOR USE BY QUALIFIED REPAIR TECHNICIANS

ONLY 230 VOLTS 1 PHASE 60 HZ

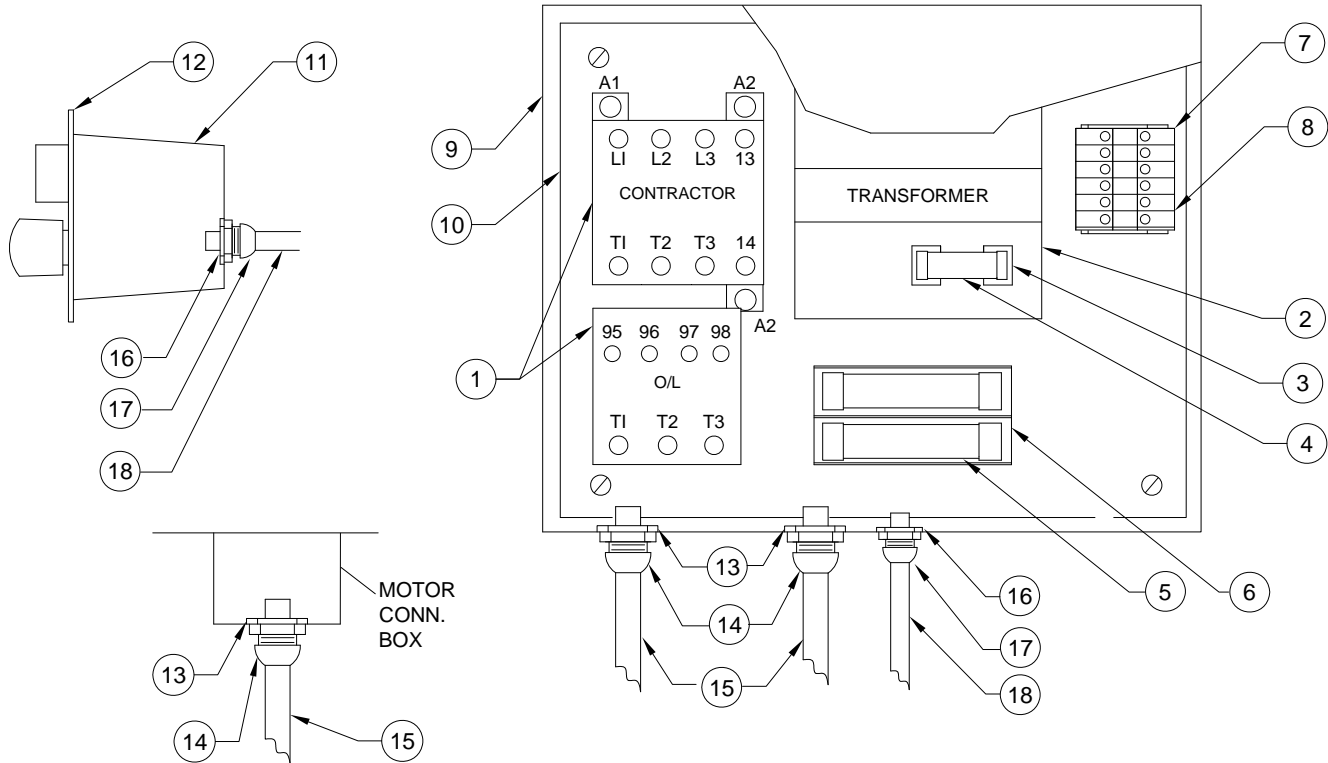

NO	PART#	DESCRIPTION	UOM
1	0093999-326	MOTOR STARTER	1
2	0093999-302	TRANSFORMER	1
3	0093999-096	CLIP-TRANSFORMER	1
4	0093999-018	FUSE	1
5	0093999-024	FUSE BLOCK	1
6	0093999-065	FUSE	2
7	0093999-069	GROUND TERMINAL	1
8	0093999-070	TERMINAL BLOCK	5
9	0093999-296	ENCLOSURE	1
10	0020999-011	MOUNTING PLATE	1
11	0093285	START STOP SWITCH	1
12	0040104	PUSH BUTTON PLATE	1
13	0095807	LOCK NUT	3
14	0095790	STRAIN RELIEF	3
15	0093999-236	CORD 10/4	1
16	0095767	LOCK NUT	2
17	0093999-132	STRAIN RELIEF	2
18	0093999-255	CORD 14/4	1

INSTRUCTIONS A42 & A52

FOR REMOVING BOWL FROM LOCKING RING.

FOR REMOVING LOCKING RING FROM GEAR BOX COVER.

FOR REMOVING CHUCK FROM GEAR BOX.

FOR BUTCHER BOY FLOOR GRINDERS

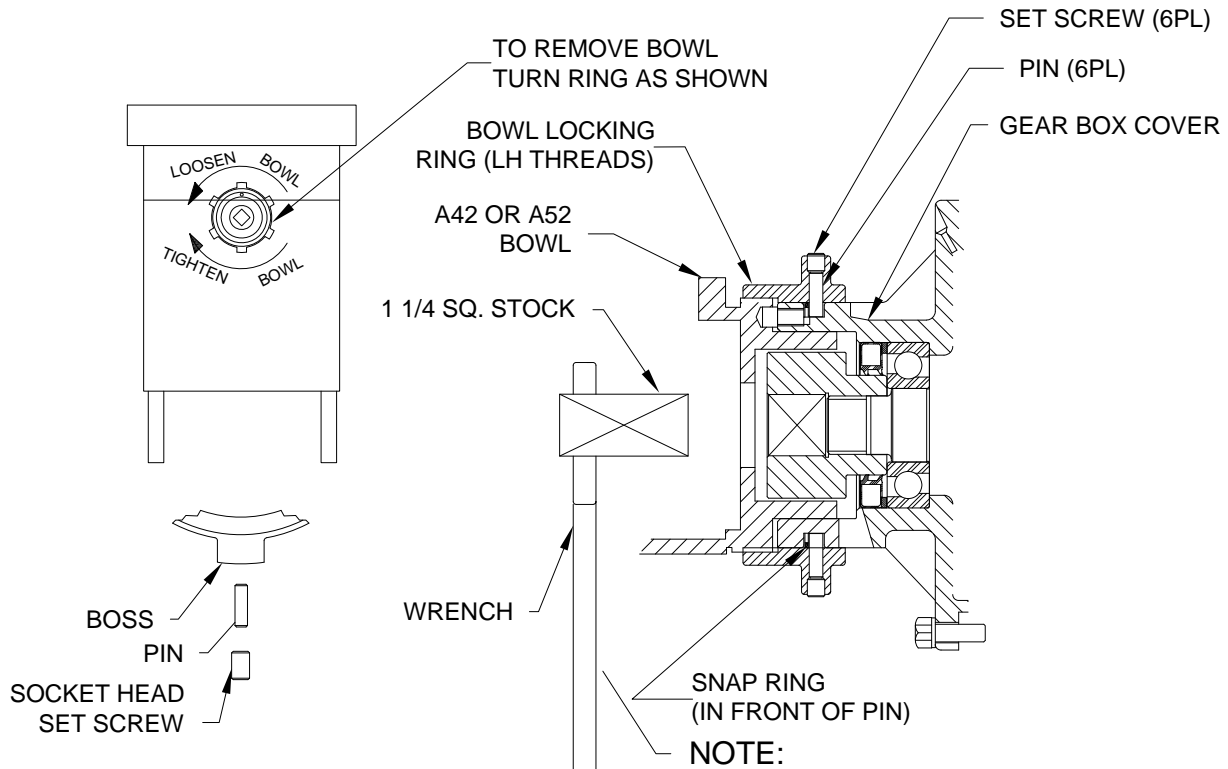

NOTE:

TO REMOVE BOWL TURN
LOCKING RING O'CLOCK WISE
WHILE HOLDING BOWL WITH
OTHER HAND

TO REMOVE CHUCK FROM
DRIVE SHAFT OF GEAR BOX, LOCK
PULLEY SHAFT IN PLACE, WITH
WITH SQUARE IN WRENCH GIVE A
SHARP RAP TO END OF WRENCH TO
BREAK CHUCK FREE. IF CHUCK IS ON
TIGHT HEAT OF TORCH MAY BE REQUIRED.

TO REMOVE LOCKING RING FROM COVER OF GEAR BOX

1. REMOVE ALL (6) SOCKET HD SET SCREWS. SPRAY INSIDE ALL (6) HOLES WITH WD-40 OR LIQUID WRENCH.
2. ALLOW IT TIME TO WORK.
3. TURN RING UNTIL ONE OF THE BOSSED ON THE LOCKEING RING IS POINTED DOWN.
4. TAP LIGHTLY ON TOP BOSS UNTIL PIN DROP OUT.
5. TURN RING SO THE NEXT BOSS IS POINTED DOWN AND REPEAT UNTIL ALL (6) PINS ARE OUT, PULL RING OFF.
6. THERE MIGHT BE SOME RESISTANCE FROM THE SNAP RING INSIDE.

LUBRICATION INSTRUCTIONS
FOR "BUTCHER BOY" FLOOR GRINDER
A42 & A52

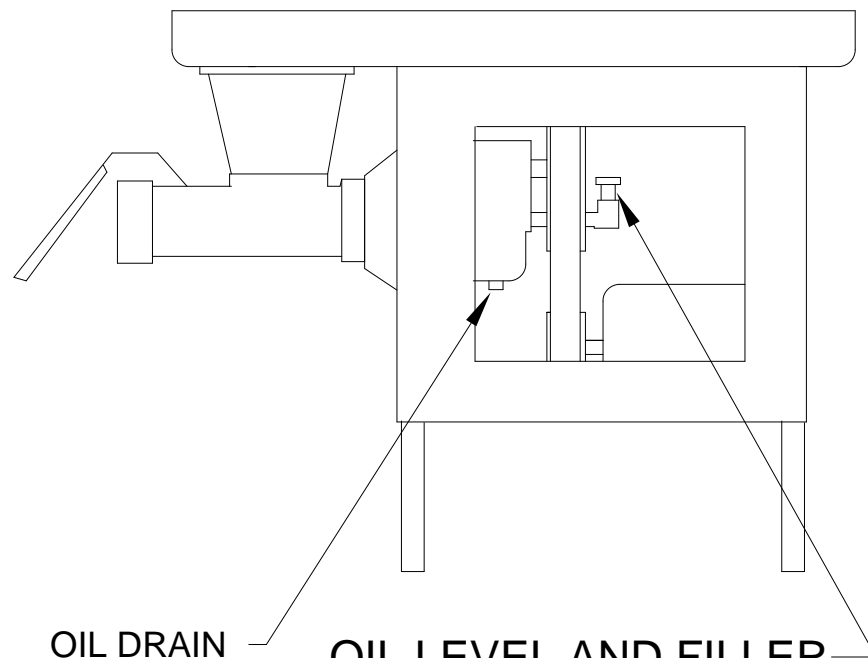

OIL DRAIN

OIL LEVEL AND FILLER
(TEXACO-REGAL G (R &O)
CHECK EVERY MONTH
CHANGE OIL EVERY 6 MONTHS

LUBRICATION

MONTHLY - CHECK OIL IN GEAR CASE
BY REMOVING "LEVEL" PLUG. IF LEVEL
IS HIGH OR OIL IS MILKY IT INDICATES
CONDENSATION. CHANGE AT ONCE.
USE REGULAR GEAR OIL "TEXACO REGAL"
(R & O) WEIGHT - ANTI RUST - ANTI FOAM -
LOW TEMPERATURE.