

# 100/42 MIXER GRINDER

REPLACEMENT PARTS MANUAL FOR  
100/42 MIXER GRINDER  
S/N 101 TO 625

(THAT WERE MANUFACTURED BY "LASAR MFG." UNTILL 1988)  
AMERICAN MEAT EQUIPMENT CORP. HAD NO CONNECTION TO THE  
DESIGN, MANUFACTURING OR SALES OF THESE MACHINES

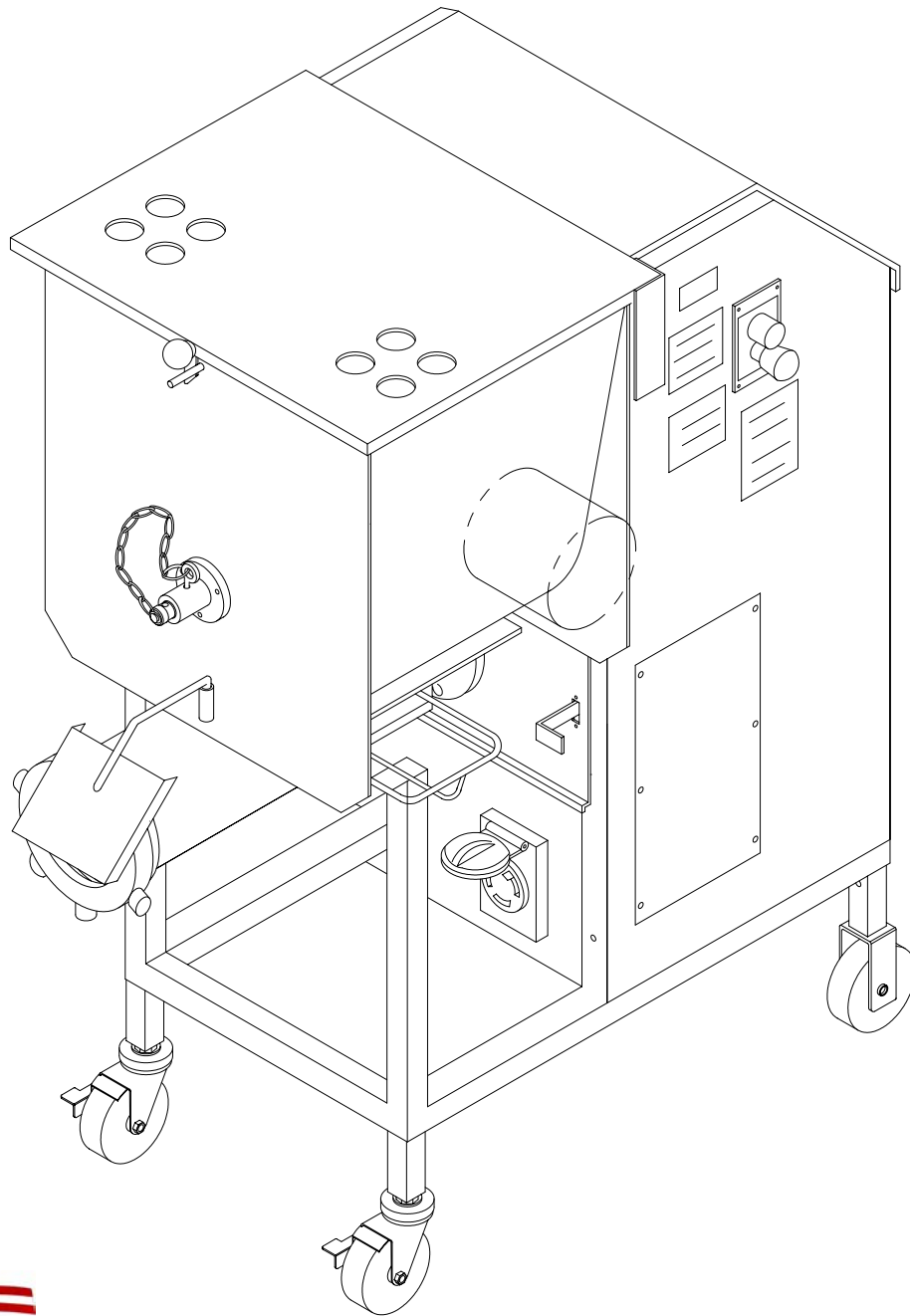

MADE IN USA

**AMERICAN MEAT EQUIPMENT CORP.**

1625 S. GREENWOOD AVE  
MONTEBELLO, CA. 90640  
PHONE: (323) 724-5348  
FAX: (323) 838-4336

# 100/42 MIXER GRINDER

## REPLACEMENT CUTTING GROUP & COMPONENTS

FOR 100/42 MIXER GRINDER

S/N 101 TO 625

(THAT WERE MANUFACTURED BY "LASAR MFG")

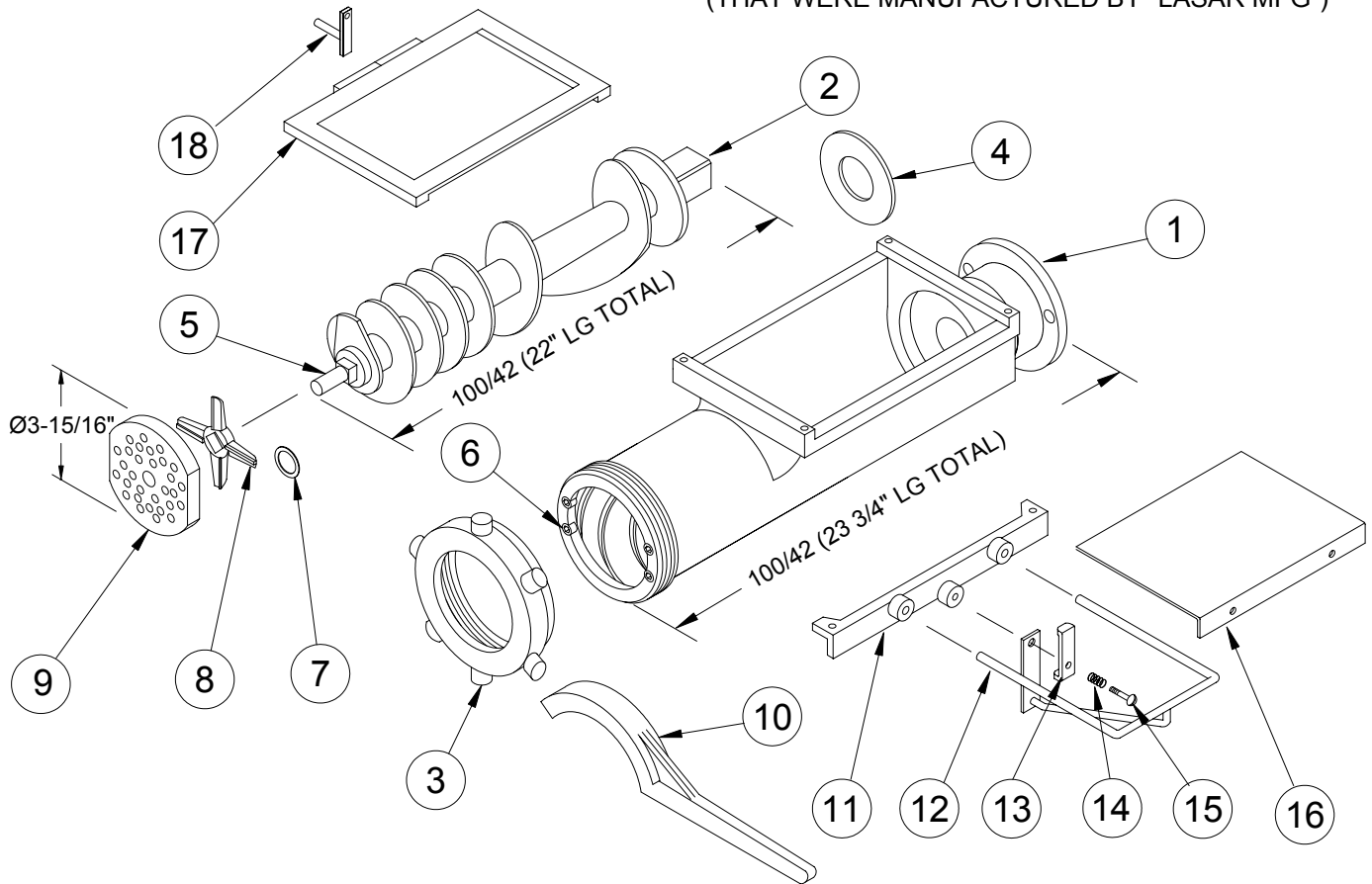

ITEM #	PART #	DESCRIPTION	QTY.	ITEM#	PART#	DESCRIPTION	QTY.
1	0040008	100/42 BOWL	1	9D	0090923	42-3/8" HOLE PLATE	1
2	0040022	100/42 FEED SCREW ASSY	1	10	0059188	42 & 52 WRENCH ALUM	1
3	0042516	42 KNIFE & PL. RING (PLATED)	1	10	0043620S	42 & 52 WRENCH SS	1
4	0059273	42 SPACER RING (BOWL & F.S.)	A/R	11	0040415	SLIDING DOOR SUPPORT	1
5	0021038	42 FEED SCREW STUD	1	12	0045110	GUIDE ROD	1
6	0059232	SCREW 42 PLATE HOLDER	1	13	0045107	DOOR LOCK	1
7	0095113	42 SHIM FEED SCREW STUD	1	14	0010314	SPRING	1
8	0090925I	42 KNIFE (INVESTMENT)	1	15	RHSS-21-24-SS	SCREW	1
8	0090925P	42 KNIFE (PREMIUM)	1	16	0045106	SHUT OFF DOOR	1
9A	0090921	42-1/8" HOLE PLATE	1	17	0040396	SLIDING DOOR FRAME	1
9B	0090922	42-3/16" HOLE PALTE	1	18	0040090	SHUT OFF LOCK	1
9C	0090920	42-1/4" HOLE PLATE	1				

# 100/42 MIXER GRINDER

## REPLACEMENT THRUST BRACKETS ASSY & SLIDING CLUTCH COMPONENTS FOR 100 MIXER GRINDER (THAT WERE MANUFACTURED BY "LASAR MFG")

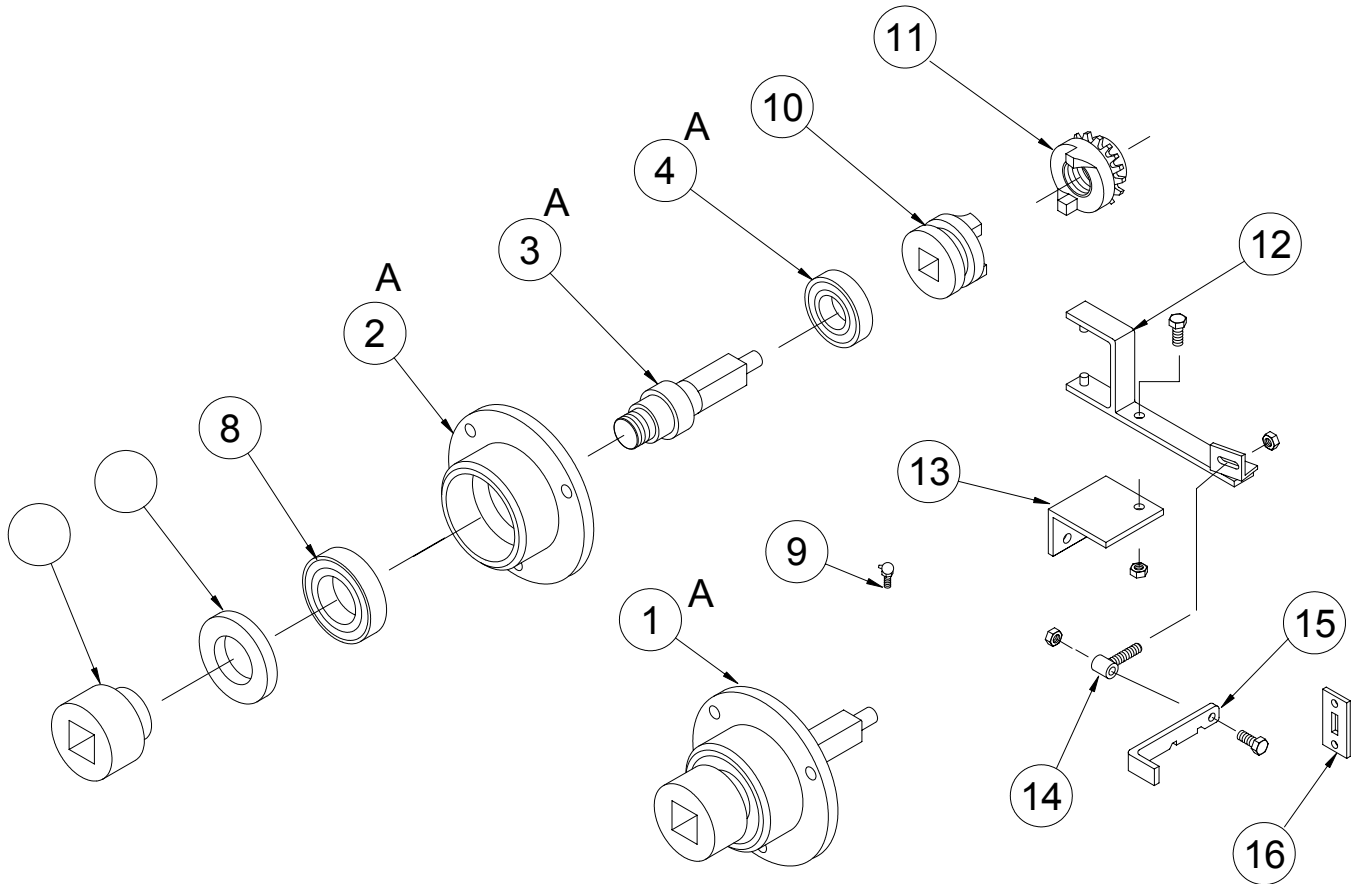

ITEM#	PART#	DESCRIPTION	QTY.
1A	0040020	100 MG THRUST BKT ASSY	1
2A	0040018	100 MG THRUST BKT	1
3A	0040019	100 MG DRIVE SHAFT	1
4A	0090341	100 MG REAR BEARING	1
6	0059060	CHUCK	1
7	0090405	SEAL	1
8	0090303	THRUST BEARING	1
9	0090603	GREASE FITTING STD 1/8-27	1
9	00404391	GREASE TUBE & FITTING KIT	1
10	0044705	SLIDING COUPLING	1
11	0040015	SPROCKET COUPLING	1
12	0040175	CLUTCH FORK	1
13	0040170	BRACKET	1
14	0040418	CLUTCH LINK	1
15	0040417	CLUTCH LEVER	1
16	0044762	CLUTCH LEVER PLATE	1

# 100/42 MIXER GRINDER

## REPLACEMENT GEAR BOX ASSY P/N 0040010 & COMPONENTS

FOR 100 MIXER GRINDER  
S/N 101 TO 625  
(THAT WERE MANUFACTURED BY "LASAR MFG.")

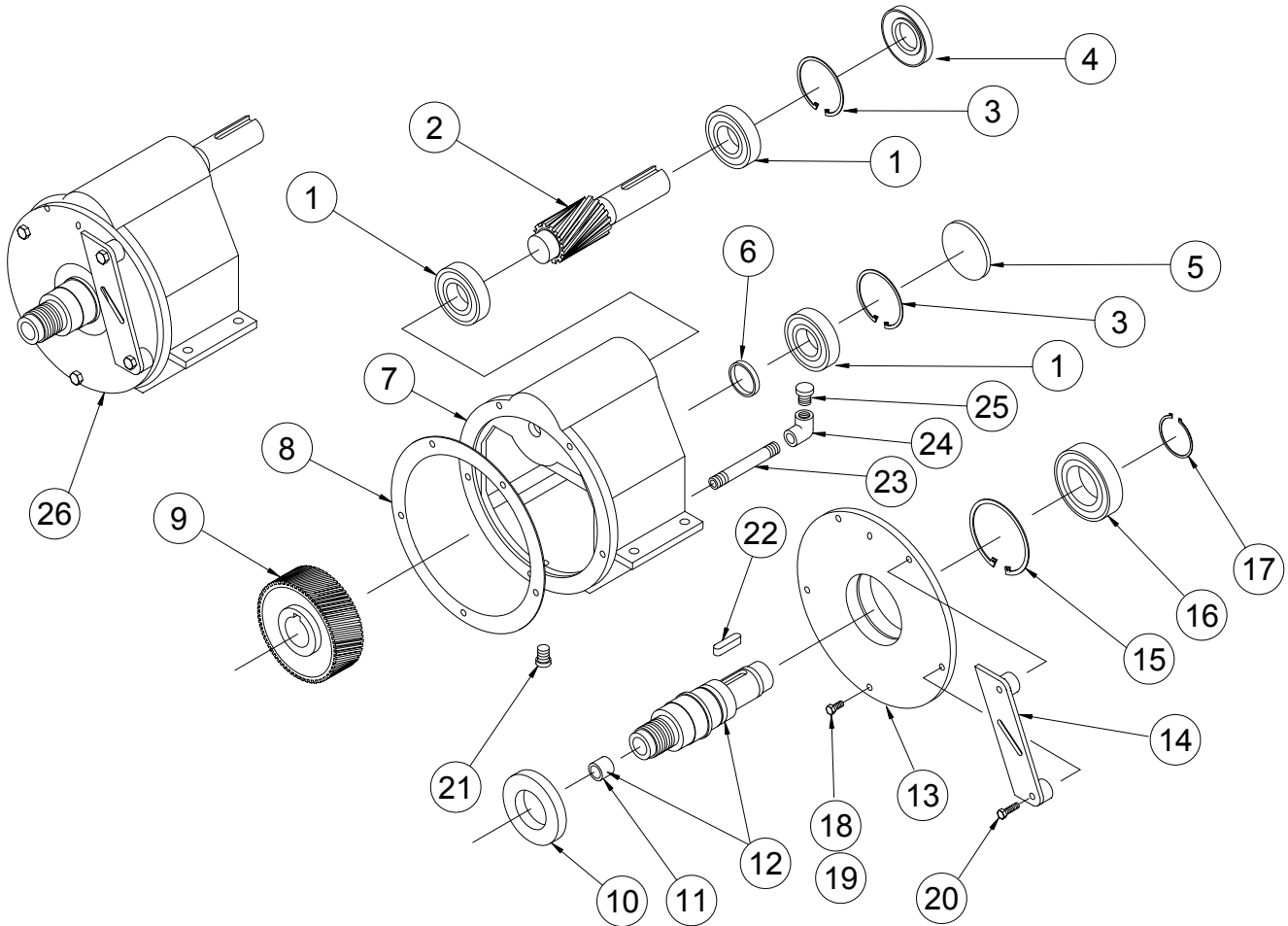

ITEM#	PART#	DESCRIPTION	QTY.	ITEM#	PART#	DESCRIPTION	QTY.
1	0090304	BEARING HOUSING	3	14	0040060	IDLER SPROCKET HOLDER	1
2	0059052	PINION & GEAR WHEEL #9	1	15	0090230	RETAININ RING-COVER	1
3	0090205	RETAINING RING HOUSING	2	16	0090322	BALL BEARING	1
4	0090404	SEAL (SMALL) HOUSING	1	17	0090251	RETAINING RING-SHAFT	1
5	0059058	PLUG	1	18	HHCS-23-20-SS	SCREW	5
6	0044766	RING	1	19	SLW-06-SS	LOCK WASHER	5
7	0040012	HOUSING-GEAR BOX	1	20	HHCS-23-28-SS	SCREW	2
8	0059061	GASKET	1	21	0095159	PIPE PLUG	1
9		GEAR (PURCHASE W #2)		22	0059249-5	KEY	1
10	0090405	SEAL (LARGE)	1	23	0090609	PIPE NIPPLE	1
11	090750	BUSHING FOR #12	1	24	0090608	PIPE ELBOW	1
12	0040011	SHAFT & BUSHING	1	25	0059067	BREATHER CAP	1
13	0040016	COVER-GEAR BOX	1	26	0040010	GEAR BOX ASSY	1

# 100/42 MIXER GRINDER

**REPLACEMENT  
TUB, LID, FRAME & COMPONENTS**  
FOR 100 MIXER GRINDER  
S/N 101 TO 625  
(THAT WERE MANUFACTURED BY "LASAR MFG.")

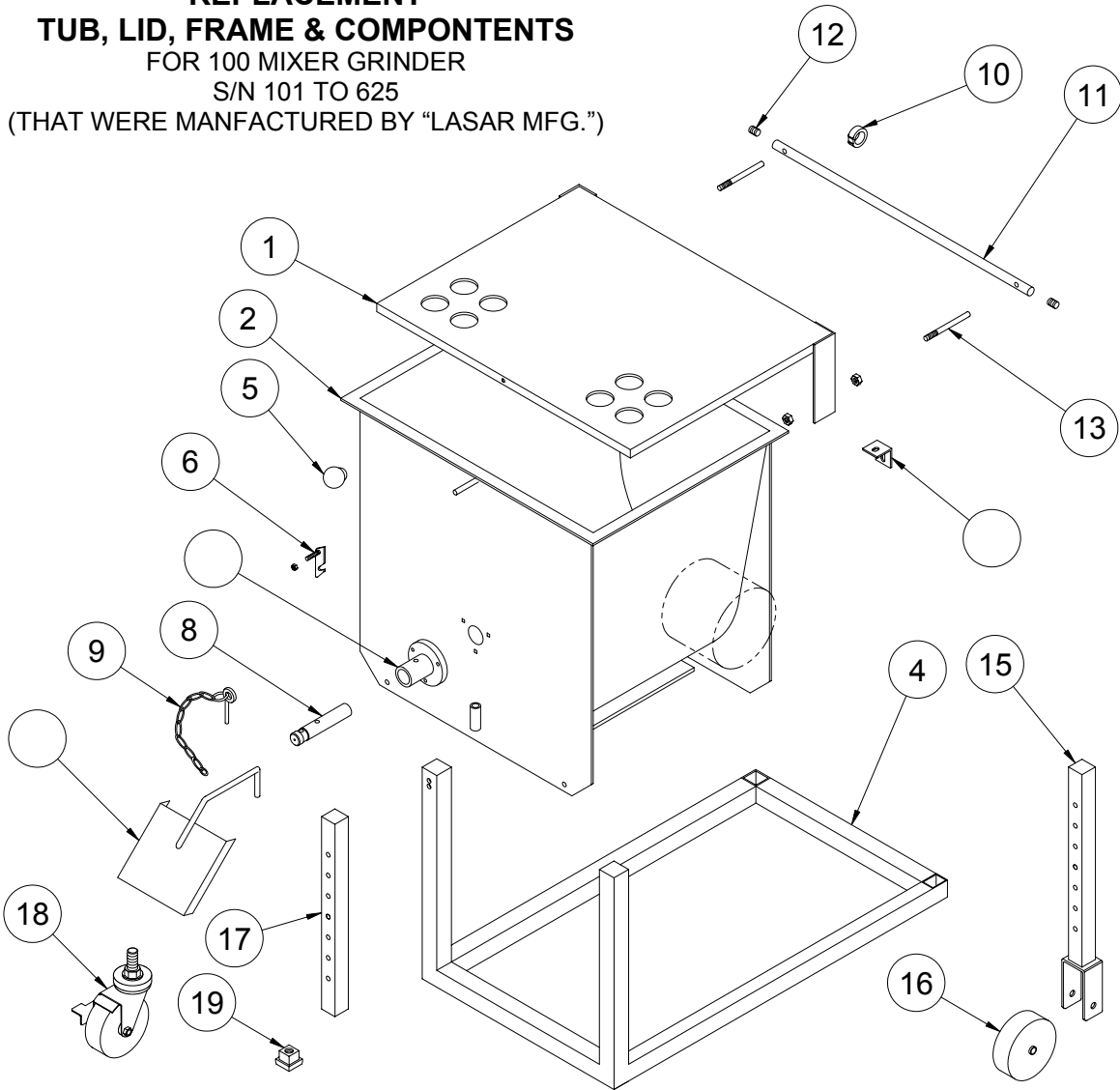

ITEM#	PART#	DESCRIPTION	QTY.	ITEM#	PART#	DESCRIPTION	QTY.
1	0040040	100 LID	1	9	0026547S	PIN & CHAIN ASSY-SS	1
2		100 TUB (REF ONLY)		10	0040437	SHUT-OFF CAM	1
		100 TUB RH CONN (REF ONLY)		11	0040067	SS LID PIVOT ROD	1
		100 TUB LH CONN (REF ONLY)		12	SHSS-28-08-SS	SCREW PIVOT ROD	2
3	0040110	100 SPURT GUARD	1	13	0026260S	SS LID STUD	2
4		SS 100 FRAME (P.O.R.)		14	0040156	ANGLE BRACKET TUB	2
5	0090638	KNOB	1	15	0040665	REAR LEG	2
6	0040138	LID LOCK HOOK W/NUT	1	16	0095173	4" CASTER WHEEL	2
7	0058116	BRACKET FRONT (PLATED)	1	17	0040671	FRONT LEG	2
7	0058116S	SS BRACKET FRONT	1	18	0095240	4" CASTER W/BRAKE	2
8	0058117	SS SHAFT FRONT	1	19	0040450	INSERT (SQ. TUBULAR LEG)	2

# 100/42 MIXER GRINDER

## REPLACEMENT PADDLE ASSEMBLY & BUSHING

FOR 100 MIXER GRINDERS  
S/N 101 TO 625

(THAT WERE MANUFACTURED BY "LASAR MFG.")

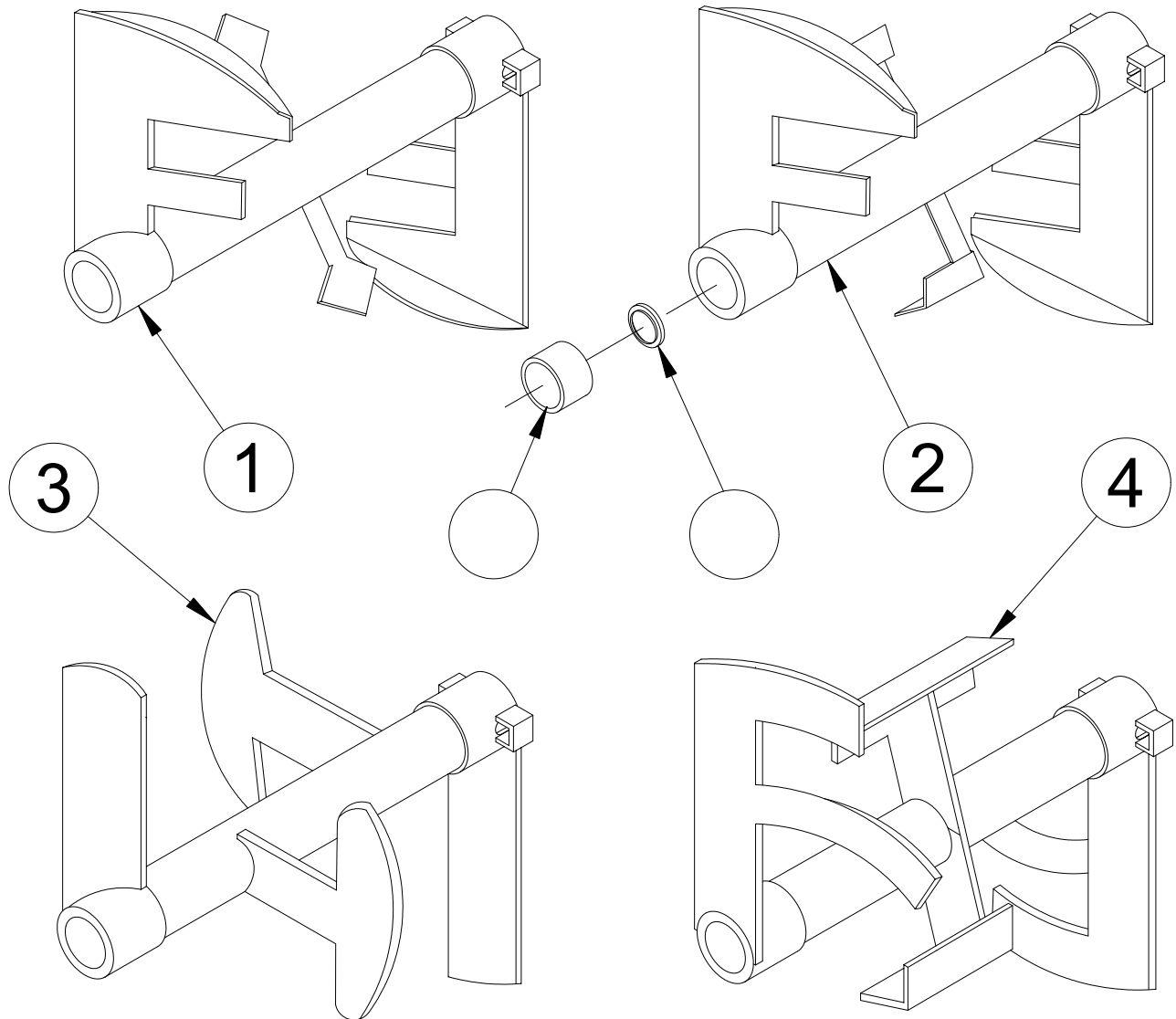

ITEM#	PART#	DESCRIPTION	QTY.
1	0040123	100 PADDLES W/ BUSHING	1
2	0040321	100 PADDLES W/ BUSHING	1
3	0040439	100 PADDLES W/ BUSHING	1
4	0040689	100 PADDLES W/ BUSHING	1
5	0040078	PLUG	1
6	0040079	NYLON BUSHING	1

# 100/42 MIXER GRINDER

## REPLACEMENT COVER & MISC.

FOR 100 MIXER GRINDERS  
CABINETS S/N 101 TO 625  
(THAT WERE MANUFACTURED BY "LASAR MFG.")

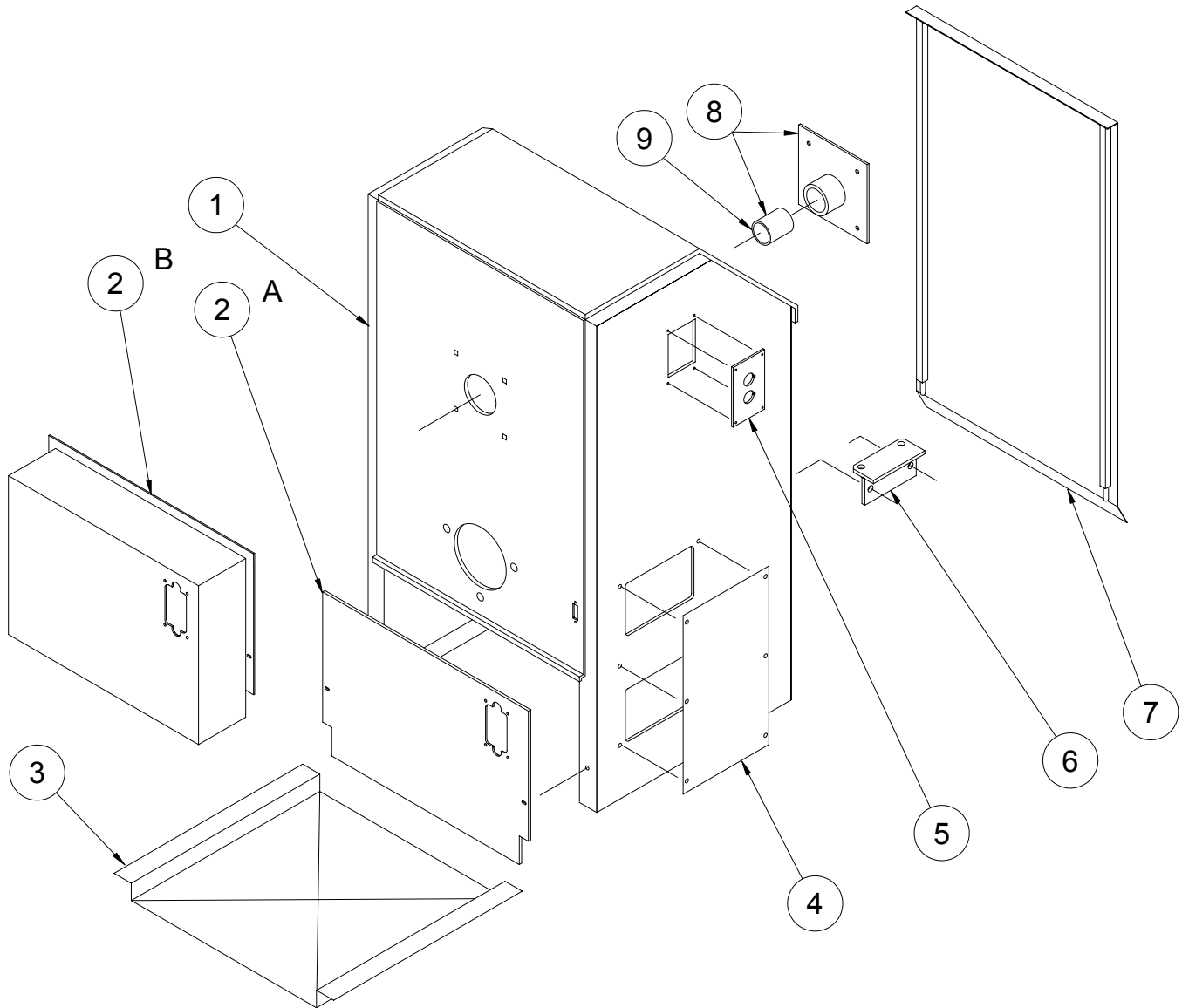

ITEM#	PART#	DESCRIPTION	QTY.
1		100 CAB. (REF ONLY)	
2A	0040103	FRONT MOTOR COVER 5, 7 1/2 & 10HP – 3PH	1
2B	0040305	EXTENDED FRONT MOTOR COVER 7 1/2 & 10HP – 1PH	1
3	0040102	TOOL PAN	1
4	0040626	ACCESS COVER	1
5	0040104	SWITCH HOLDER	1
6	0040064	GEAR BOX MOUNT	2
7	0040630	BELT COVER	1
8	0040130S	BEARING BRACKET WITH BUSHING	1
9	0090725	BUSHING BEARING BRACKET	1

# 100/42 MIXER GRINDER

**REPLACEMENT  
DRIVE COMPONENTS**  
FOR 100/42 MIXER GRINDERS  
(THAT WERE MANUFACTURED BY "LASAR MFG.")

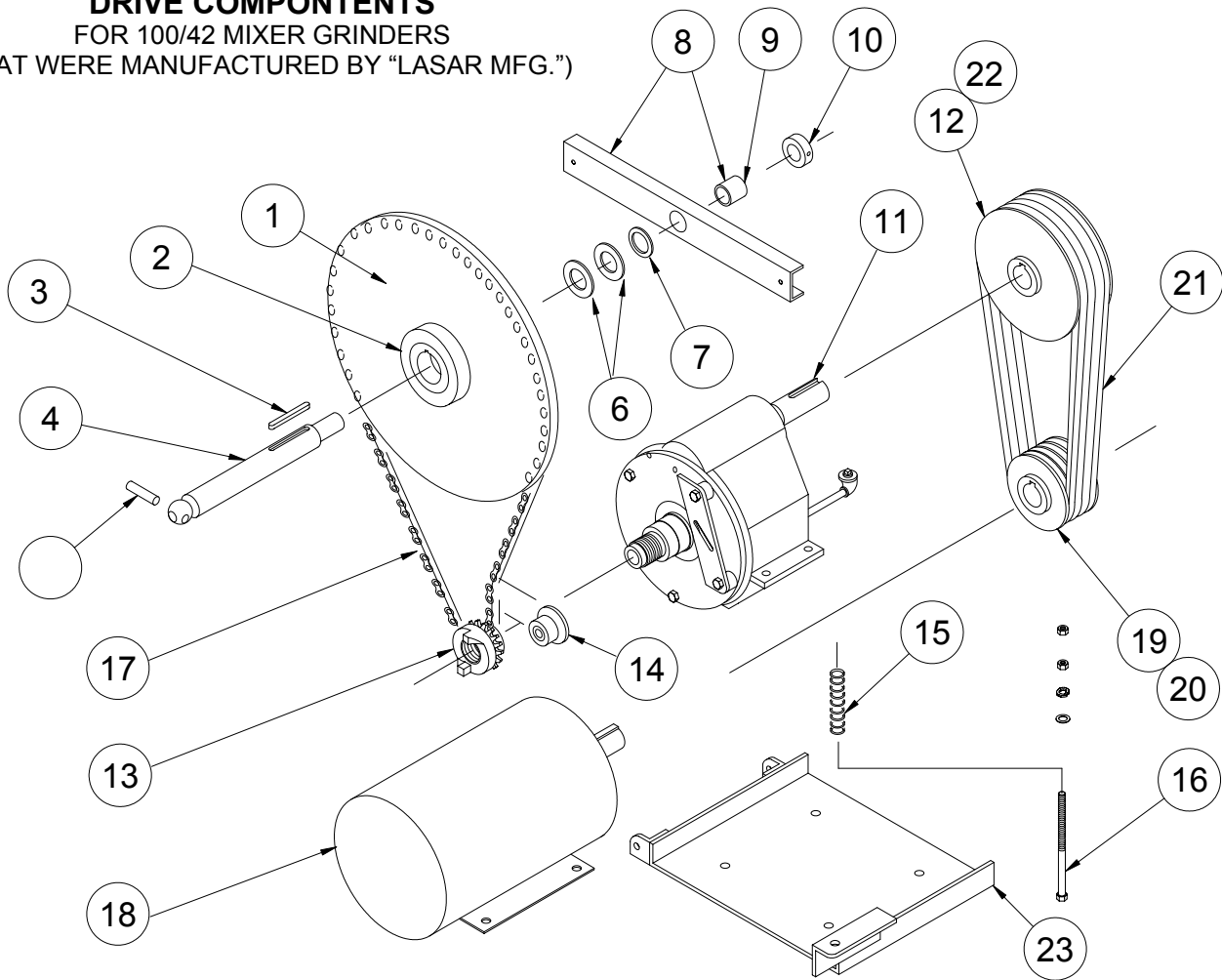

ITEM#	PART#	DESCRIPTION	QTY.	ITEM#	PART#	DESCRIPTION	QTY.
1	0090180	SPROCKET	1	10	0095077	COLLAR (PLATED)	1
2	0090152	HUB	1	10	0095077S	COLLAR SS	1
3	0059248-9	KEY	1	11	0040010	GEAR BOX ASSY	1
4	0040023S	DRIVE SHAFT PADDLES	1	12	0090153	BUSHING DRIVEN PULLEY	1
5	0045048	DRIVE PIN	1	13	0040015	SPROCKET COUPLING	1
6	0044662	FIBER SPACER	1	14	0044516	IDLER SPROCKET	1
7	0044521	SHIM	1	15	0043157	TENSION SPRING	1
8	0044344S	SUPPORT W/BUSHING	1	16	0043155	TENSION BOLT	1
9	0090718	BUSHING	1	17	0091136	CHAIN ASSEMBLY	1

ITEM 18	ITEM 19	ITEM 20	ITEM 21	ITEM 22	ITEM 23
MOTOR	MOTOR PULLEY	MOTOR HUB	BELT	DRIVEN PULLEY	MOTOR MOUNT
PART#	PART#	PART#	PART#	PART#	PART#
0092186 5HP, 3PH	0090199-107 3GR	0090176	0090519	0090110 3GR	0040109
0092185 5HP, 1PH	0090199-107 3GR	0090176	0090519	0090110 3GR	0040109
0092230 7.5HP, 3PH	0090199-107 3GR	0090142	0090519	0090110 3GR	0040100
0092229 7.5HP, 1PH	0090199-107 3GR	0090142	0090518	0090110 3GR	0040105



# 100/42 MIXER GRINDER

## REPLACEMENT ADAPTORS & TUB PLUG ASSEMBLY

FOR 100 MIXER GRINDERS  
S/N 101 TO 625

(THAT WERE MANUFACTURED BY "LASAR MFG.")

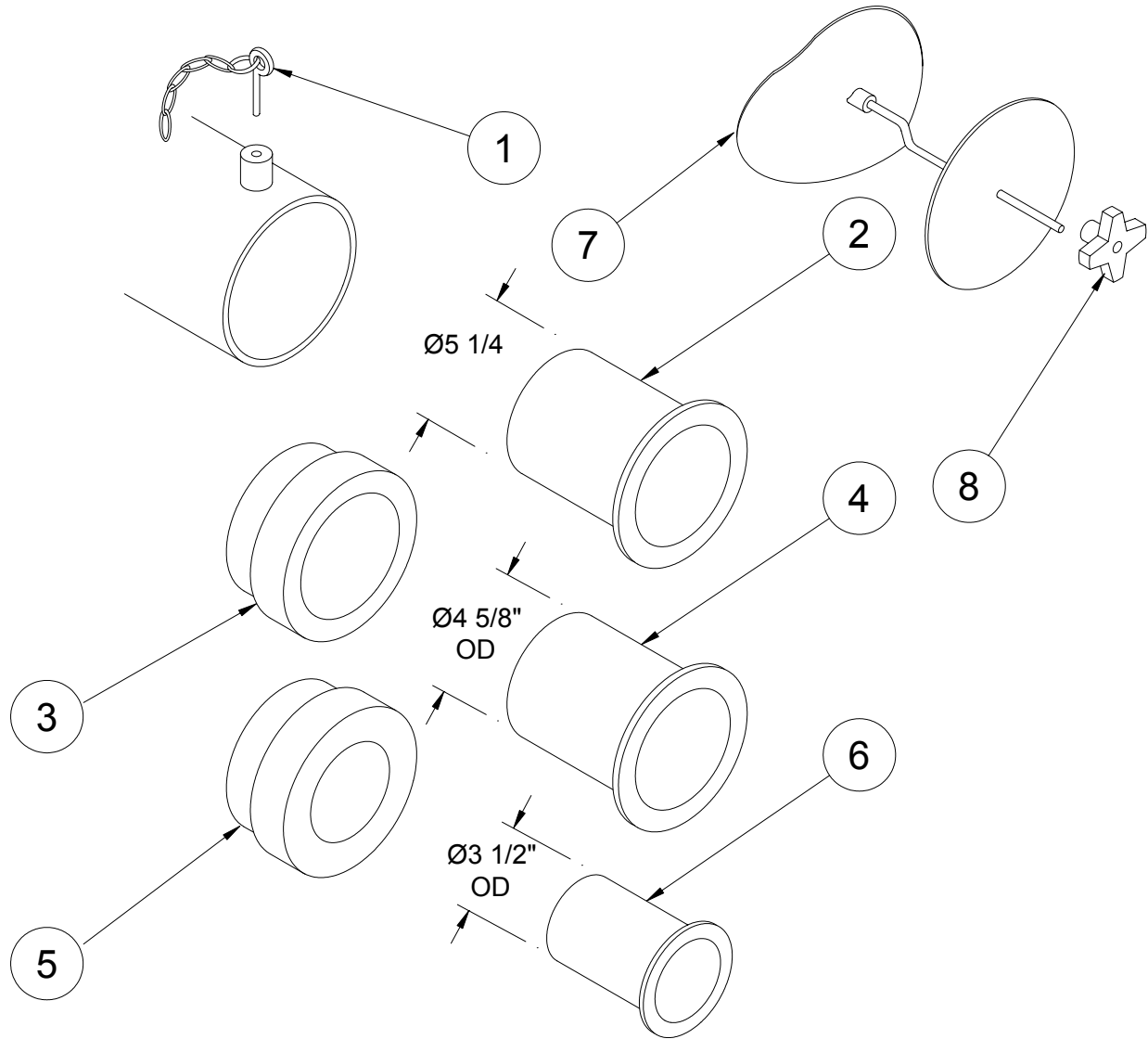

ITEM#	PART#	DESCRIPTION	QTY.
1	0045319	PIN & CHAIN ASSEMBLY	1
2	0057170	56 CONNECTOR TUBE (HORN)	1
3	0053033	56 TO 52 REDUCER	1
4	0053030	52 CONNECTOR TUBE (HORN)	1
5	0042548	56 TO 42 REDUCER	1
6	0045319	42 CONNECTOR TUBE (HORN)	1
7	0040560	100 & 200 TUBE PLUG ASSEMBLY	1
8	0095257	LOCKIN KNOB	1

# BUTCHER BOY 100/42 MIXER GRINDER

## DEFINITE PURPOSE STARTERS AND COMPONENTS

FOR 100/42 MIXER GRINDERS

S/N 101 TO 625

(THAT WERE MANUFACTURED BY "LASAR MFG.")

### NOTE:

CHECK THE MOTOR TO CONFIRM THE AMP RATING FOR THE HP & VOLTAGE TO BE USED

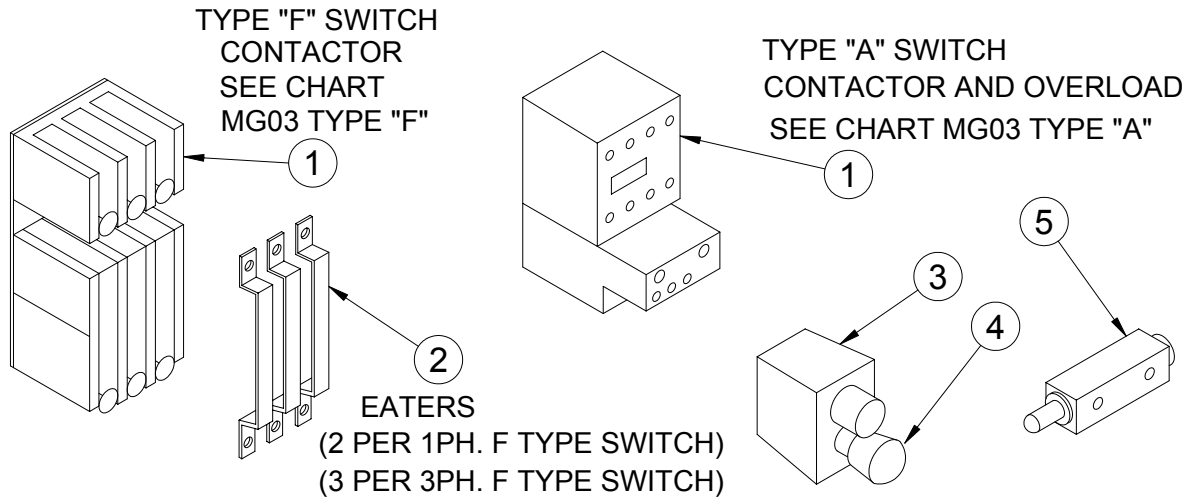

HP	PH	VOLTAGE				"F" TYPE SWITCH WITH HEATERS	"F" TYPE HEATERS (QTY #3)		"A" TYPE SWITCH WITH OVERLOAD
		575V	460V	230V	200V	PART#	#	PART#	PART#
5	1			28.0		0093011	E70	0093547	0093659
	3	5.6				0093033	E46	0093532	0093648
	3		7.2			0093008	E48	0093534	0093644
	3			14.4		0093007	E57	0093539	0093642
	3				16.0	0093007	E60	0093542	0093642
7 1/2	1			40.0					
	3	8.3				0093010	E51	0093536	0093649
	3		10.6			0093008	E54	0093538	0093645
	3			21.2		0093011	E62	0093544	0093651
	3				25.0	0093011	E66	0093561	0093650

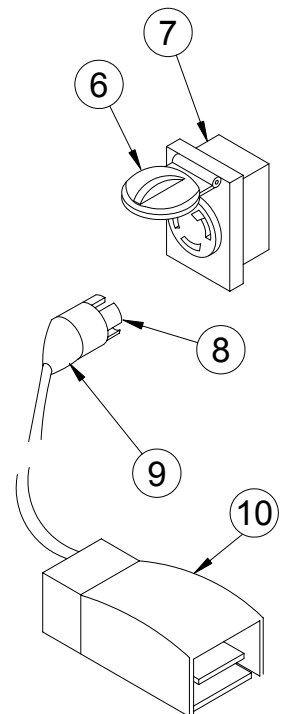

ITEM#	PART#	DESCRIPTION	QTY.
3	0093290	STOP BUTTON ASSEMBLY	1
4	0093285	PUSH BUTTON SWITCH ASSEMBLY	1
5	0093271	LIMIT SWITCH	1
6	0093118	COVER FOR RECEPTACLE	1
7	0093115	FOOT SWITCH RECEPTACLE (F)	1
8	0093114	FOOT SWITCH PLUG (M)	1
9	0093117	BOOT FOR FOOT SWITCH PLUG	1
10	0093052	FOO SWITCH	1